

VOT6506E

CENTRAL BATTERY UNIT FOR EMERGENCY LIGHTING

Installation and maintenance instructions TKT65XXB(P)



KEEP IN A SAFE PLACE FOR LATER USE



Teknoware Oy, Ilmarisentie 8, 15200 LAHTI, puh. (03) 883 020, fax (03) 8830 260
www.teknoware.fi e-mail: emexit@teknoware.fi

TKT65XXB product description

REV.6; 15.2.2017

Table of contents

Page

1. Product description	3
1.1. Manufacturer	3
1.2. Type	3
1.3. General description	3
1.4. Technical specifications	3
1.5. Directives and standards	4
2. Functional description	4
2.1. Task of the unit	4
2.2. Group outputs	5
2.3. Charging	5
2.4. Mains voltage limits	6
2.5. Battery voltage limits	6
2.6. Alarm relay outputs	6
2.7 Remote control	6
3. System installation	6
4. Implementation	6
4.1. Setting the charging current	7
5. Use	7
6. Maintenance	7
6.1 Maintenance procedures	7
6.2. Replacing the batteries	8
7. Removing from use	8

Appendix:

Appendix 1. Control panel	9
Appendix 2. Connections	10
Appendix 3. Placement of the parts	11
Appendix 4. Dimensions	12
Appendix 5 Wiring diagram	13
Appendix 6 Battery Layout Options	14



Teknoware Oy, Ilmarisentie 8, 15200 LAHTI, puh. (03) 883 020, fax (03) 8830 260
 www.teknoware.fi e-mail: emexit@teknoware.fi

1. Product description

1.1. Manufacturer

Teknoware Oy
Ilmarisentie 8
FI-15200 Lahti
FINLAND

1.2. Type

TKT6506B Max. 6 circuits 230 V AC/DC
TKT6512B Max. 12 circuits 230 V AC/DC
TKT6518B Max. 18 circuits 230 V AC/DC
TKT6524B Max. 24 circuits 230 V AC/DC

1.3. General description

TKT65XXB central battery unit is based on the Teknoware TKT series product family. This family is designed and manufactured according to the EN 50171 standard.

In normal situations, the unit works from the 230 VAC mains supply, by maintaining the battery charging level, and by feeding a voltage of 230 VAC, to the maintained output circuits. When the mains voltage fails, or it drops below 180 V, the unit changes to battery use. This connects a voltage of 220 VDC to the non-maintained circuits, and the voltage feed to the maintained circuits changes from 230 VAC to 220 VDC. The battery feed works as long as the mains voltage remains unavailable, or the battery voltage is lowered to the deep discharge limit (173 V).

The batteries (18 pcs) for the unit always require a separate battery cabinet.

All the functions related to the use of the unit can be performed from the control panel that also includes display LEDs to indicate the operation status. The panel functions are presented in Appendix 1.

1.4. Technical specifications

Mains connection:	230 VAC 50 Hz 1~
Output voltage:	normal mode: 230 VAC, emergency mode: 220 VDC
Battery voltage:	220 VDC
Battery charging time:	12 h
Max input power TKT6506B:	2,250 VA
Max input power TKT6512B:	2,250 VA
Max input power TKT6518B:	3,680 VA
Max input power TKT6524B:	3,680 VA
Ambient temperature range:	+10 ... +30°C
Input fuse:	Circuit breaker 10 AT (TKT6506B)
Input fuse:	Circuit breaker 16 AT (TKT6512B, TKT6524B, TKT6512B)
Group fuses:	5x20mm glass tube 4 AT
Battery fuse TKT6506B:	2 x 10 A plug cartridge S 10 A / 380 V Neozed
Battery fuse TKT6512B:	2 x 16 A plug cartridge S 16 A / 380 V Neozed
Battery fuse TKT6518B:	2 x 35 A plug cartridge S 35 A / 380 V Neozed
Battery fuse TKT6524B:	2 x 63 A plug cartridge S 63 A / 380 V Neozed
Charging circuit fuses:	5 x 20 mm glass tube 6,3 AT
IP class of the casing:	IP20 (basic models), IP34 (cabinet construction TKT65xxBP)



Teknoware Oy, Ilmarisentie 8, 15200 LAHTI, puh. (03) 883 020, fax (03) 8830 260
www.teknoware.fi e-mail: emexit@teknoware.fi

Unit type	Input from the network	Maintained outputs	Non-maintained outputs	Total load capacity with 1 h and 3 h battery mode duration
TKT6506B	2250 VA	6 x 250 W Max. 1,200 VA	250 W / circuit	1 h 1,500 W 18 x 24 Ah 3 h 1,500 W 18 x 38 Ah
TKT6512B	2,250 VA	12 x 250 W Max. 1,200 VA	250 W / circuit	1 h 3,000 W 18 x 38 Ah 3 h 3,000 W 18 x 65 Ah
TKT6518B	3,680 VA	18 x 250 W Max. 2,580 VA	250 W / circuit	1 h 4,500 W 18 x 38 Ah 3 h 3,340 W 18 x 65 Ah
TKT6524B	3,680 VA	24 x 250 W Max. 2,580 VA	250 W / circuit	1 h 6,000 W 18 x 65 Ah 3 h 2,400 W 18 x 65 Ah

The unit is equipped with a mains fuse F1 in the connecting terminal and with a battery circuit fuses F2 and F3. The fuses F1-F6 for the output groups are on separate relay cards TS10-TS13. The charging system of the unit is equipped with temperature compensation of the battery charging voltage, which is about 0.06 V/°C (5 mV/°C/cell).

The luminaires used with the unit must be suitable both for AC and DC supply.

1.5. Directives and standards

The following directives and standards were applied in designing and manufacturing the unit:

Quality:	ISO 9001:	2000	(certified quality system)
Environment:	ISO 14001:	1996	(certified environment system)
Electrical safety:	72/23/EEC, 93/68/EEC		LVD directive
Device standard:	EN 50171:	2001	Central power supply systems
	EN 50272-2	2001	Safety requirements for secondary battery installations Part 2: Stationary batteries
Electromagnetic compatibility:	89/336/EEC, 92/31/EEC		EMC directive
	EN 50081-1:	1992	Residential, commercial and light industry, generic emission standard
	EN 61000-6-2:	1999	Part 6-2, Generic standards – Immunity for industrial environments

2. Functional description

2.1. Task of the unit

In normal mode, the task of the central battery unit is to monitor the mains voltage, and to charge the batteries, as well as to feed the maintained output circuits. During a power failure, the unit feeds the maintained and non-maintained output circuits, with the energy stored in the batteries.

Explanations of signal LEDs and buttons are available in Appendix 1.



Teknoware Oy, Ilmarisentie 8, 15200 LAHTI, puh. (03) 883 020, fax (03) 8830 260
www.teknoware.fi e-mail: emexit@teknoware.fi

2.2. Circuit outputs

The central battery unit outputs can be connected by the “Mode” connectors (see page 6) in steps of 2 circuits, either as maintained or non-maintained circuits.

2.3. Charging

After a power failure or after installing the unit, the unit charges the batteries with constant current, until the battery voltage reaches the maintenance voltage level. The charging current can be selected from the charger module card with a DIP switch. See section 4.1. Setting the charging current.

Network LED is lit, when the battery is charging

Charging LED is blinking, when the battery voltage has not reached the maintenance voltage

The charging LED is lit when the battery voltage has reached maintenance voltage.

2.4. Main voltage limits

When the main voltage drops below 180 V, the unit changes to battery use.

Battery use LED is lit

When the network returns or gets higher than 195 V, the unit changes again to mains use, and starts to charge the batteries.

Main use LED is lit

Charging LED is blinking or lit

2.5. Battery voltage limits

If the battery voltage rises over 260 V in normal mode, an over-voltage alarm is given.

Main use LED is lit

Over-voltage LED is lit

Battery fault LED is lit

Internal fault LED is lit

If the battery voltage drops under 228 V in normal mode, an under-voltage alarm is given.

Main use LED is lit

Under-voltage LED is lit

Battery fault LED is lit

Internal fault LED is lit

When the unit is in battery mode, and the voltage drops below 195 V, a deep discharge alarm is given.

Deep discharge LED is blinking

Internal fault LED is lit

When the unit is in battery mode, and the battery voltage falls below 173 V, the unit goes into deep discharge protection mode, where the battery discharge is stopped.

Battery use LED is lit

Deep discharge LED is lit

Internal fault LED is lit

Deep discharge LED stays lit until it is reset from the *reset/test* button. Resetting is possible only after the mains supply has returned.

The unit can be switched to emergency mode also remotely, if this feature is used.

Main use LED is blinking

Battery use LED is lit



If the batteries are disconnected, the charger does not charge, the battery fuse is blown, or the batteries do not accept charging current, the following alarms are displayed on the screen:

Main use LED is lit
Under-voltage or over-voltage LED is lit
Battery fault LED is lit
Internal fault LED is lit

2.6. Alarm relay outputs

Fault alarm: - Alarms, when a fault is detected.
 Emergency mode alarm: - Alarms when the unit is in battery mode.

2.7. Remote control

Remote control on: - network use LED is blinking, and the battery use LED is lit

3. System installation

Only a qualified electrical worker may perform system installation and implementation. No connections in the unit shall be made with voltage on!

System installation takes place according to the electrical design plan, or the electrical work explanation.

In the starting phase, the main switch must be in position 0 and the battery fuse must not be connected. The batteries are always placed in a separate battery cabinet. The batteries are connected in series 18 x 12 V to the + (red) and – (black) cables reserved for them. The battery **temperature sensor shall be placed between the batteries**. Check the battery polarity.

Bring the mains supply cable to the connectors L, PE and N. After this, connect the maintained and non-maintained circuits to circuit boards TS10-TS13/ CIRCUITS 1-6. The circuit fuses are located in fuse holders F1-F6 (see Appendix 2, connections). The outputs are connected by the "Mode" wire loops (see connections, Appendix 2), either as maintained or non-maintained:

"Mode" loop connected: maintained circuit
 "Mode" loop not connected: non-maintained circuit

"Mode" loop affects always two circuit outputs.

Mode AB circuits 1-2
 Mode CD circuits 5-6
 Mode EF circuits 3-4

At the factory, all the circuits in the unit are set as maintained circuits. The circuits that are required for non-maintained use, must have the corresponding "Mode" wire loop removed.

The alarms and the remote control switch are connected to the connectors presented in Appendix 2.

4. Implementation

Only a qualified electrical worker may perform system installation and implementation.

The type label located inside the unit shall be marked with the total load connected to the unit, and the battery mode duration, with rated load, shall be marked in the two empty columns.

At the factory, the central battery unit and the luminaires are subjected to voltage withstand test, insulation resistance test and grounding connectivity tests, according to the Low Voltage Directive. During the final insulation resistance testing of the installed system, the mains input and circuit outputs of the unit must be short-circuited.



Teknoware Oy, Ilmarisentie 8, 15200 LAHTI, puh. (03) 883 020, fax (03) 8830 260
 www.teknoware.fi e-mail: emexit@teknoware.fi

When the required installations and cabling inspections and tests have been carried out, connect the battery fuses F2 and F3 and switch on the main switch S1.

Main use LED is lit

Charging LED is blinking, when the battery voltage has not reached the maintenance voltage

The charging LED is lit when the battery voltage has reached maintenance voltage.

4.1. Setting the charging current

The charging current is set to the minimum value at the factory. The charging current must be set/checked in the following way:

Set the current from the charging card TS5 DIP switch as indicated in the instructions.
NOTE! The charging current must ALWAYS be set/checked according to the number of ampere hours (Ah) of the batteries used. If the value has not been set correctly, the batteries may get damaged. When all the Dip switches are in the OFF position, the charging current is set for the batteries of 65 Ah. Other battery sizes are according to the label. The label includes 17 Ah charging current setting as an example

**NOTE! ALWAYS SET THE CHARGING CURRENT WITHOUT VOLTAGE!
ONLY ONE DIP SWITCH CAN BE SWITCHED ON!**

- 1= 7 Ah
- 2= 17 Ah
- 3= 24 Ah
- 4= 38 Ah
- ALL OFF 65 Ah
- 5= NC
- 6= NC

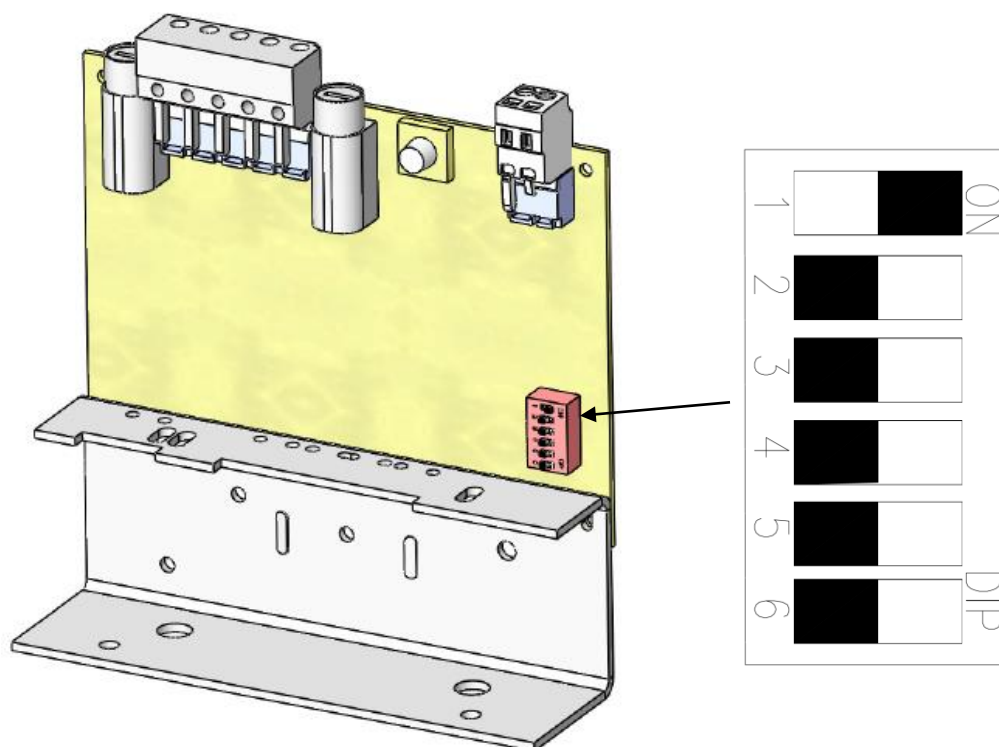

5. Usage

According to the EN 50172 standard, the user must check the functioning of the maintained luminaires visually every day. Additionally, it must be visually checked, that the indicators of central battery unit show correct operation. If the maintained luminaires connected in the system do not work, and/or an alarm LED is lit on the unit (see Appendix 1), the person responsible for servicing the system shall be notified.

6. Maintenance

Maintenance of the emergency lighting system shall be arranged according to the requirements of the authorities. The maintenance of the complete system should be performed according to the EN 50172 standard.

Only a professional electrician may perform maintenance tasks that require opening the unit or the battery casing.

6.1 Maintenance procedures to be performed according to the EN 50172 standard

- Daily checking that the front panel indicators of the central battery unit are ok.
- Monthly checking that all luminaires operate on battery mode
- Annually full battery duration test
- Tests and inspections made must be recorded in the emergency lighting system maintenance manual which shall be shown to the authorities when requested

6.2. Replacing the batteries

The batteries shall be changed in the following order:

- take off the lid of the unit
- disconnect the battery fuses F2 and F3 (Main use LED is lit, under-voltage LED is lit)
- turn the main switch S1 to position 0 (display LEDs go out = unit has no voltage)
- take off the lids of the battery cabinet(s)
- disconnect the cables between the batteries and central battery unit (minus cable first)
- disconnect the jumper cables between the batteries
- remove the batteries and install new ones
- place the temperature sensor between the batteries
- connect the battery cables (note the polarity and insulation distances)
- attach the battery casing lid
- turn in the battery fuses F2 and F3
- attach the lid of the unit
- turn the main switch S1 to position 1
- check the operation of the unit

7. Removing from use

When removing the unit system and its components from use, take the following into consideration:

Batteries and fluorescent lamps are hazardous waste. Metallic parts can be delivered to aluminium or steel waste. Wires, connectors and printed board assemblies are electronics waste. Plastic parts should be sorted according to material markings.



APPENDIX 1

Control panel

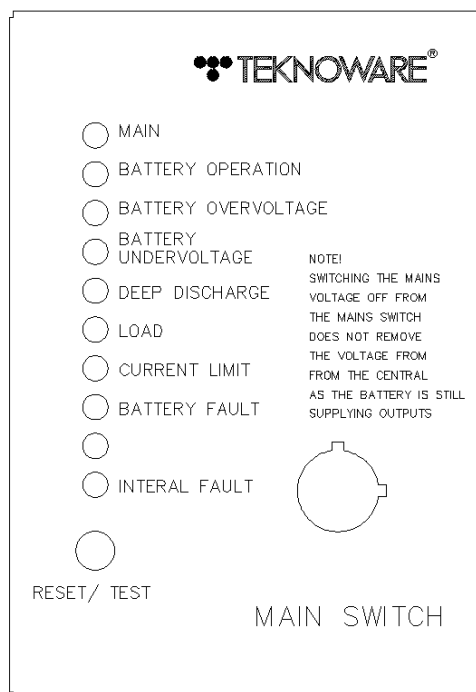

Explanations of the indicator LEDs:

LED:	Explanation:
MAIN	- The unit operates normally from the mains network.
BATTERY OPERATION	- The unit is on emergency mode (supply from battery)
BATTERY OVER-VOLTAGE	- The battery voltage is higher than normal (over 260 V)
BATTERY UNDER-VOLTAGE	- The battery voltage is lower than normal (under 228 V)
DEEP DISCHARGE	- The deep discharge protection of the battery has acted (the voltage has dropped under 173 V during a power failure)
LOAD	- The battery is being recharged
CURRENT LIMIT	- Indicates a too high recharging current
BATTERY FAULT	- Indicates a failure of the battery or the battery circuit
INTERNAL FAULT	- General fault notification. Lit if the battery over-voltage, battery under-voltage, deep discharge, current limit or battery fault LED is lit
"MAINS SUPPLY" LED IS BLINKING AND "BATTERY USE" LED IS LIT	- The unit is in emergency mode controlled by the remote control switch
"MAINS SUPPLY", "BATTERY UNDER-VOLTAGE", "BATTERY FAULT" AND "INTERNAL FAULT" LED IS LIT	- There is a fault in the charging circuit (batteries are not charged)

Buttons

Reset/Test	Deep discharge protection alarm reset: press the button for 1 s to reset the alarm. Short-time battery use test: pressing the button for 5 s switches the central battery unit to battery use for 8 minutes. During the test, Battery use LED is lit and Network LED is blinking. After this, the unit returns to normal mode.
Main switch	Disconnects the mains supply. Battery mode test can be performed by turning the main switch to position 0.



Teknoware Oy, Ilmarisentie 8, 15200 LAHTI, puh. (03) 883 020, fax (03) 8830 260
www.teknoware.fi e-mail: emexit@teknoware.fi

APPENDIX 2

Connections

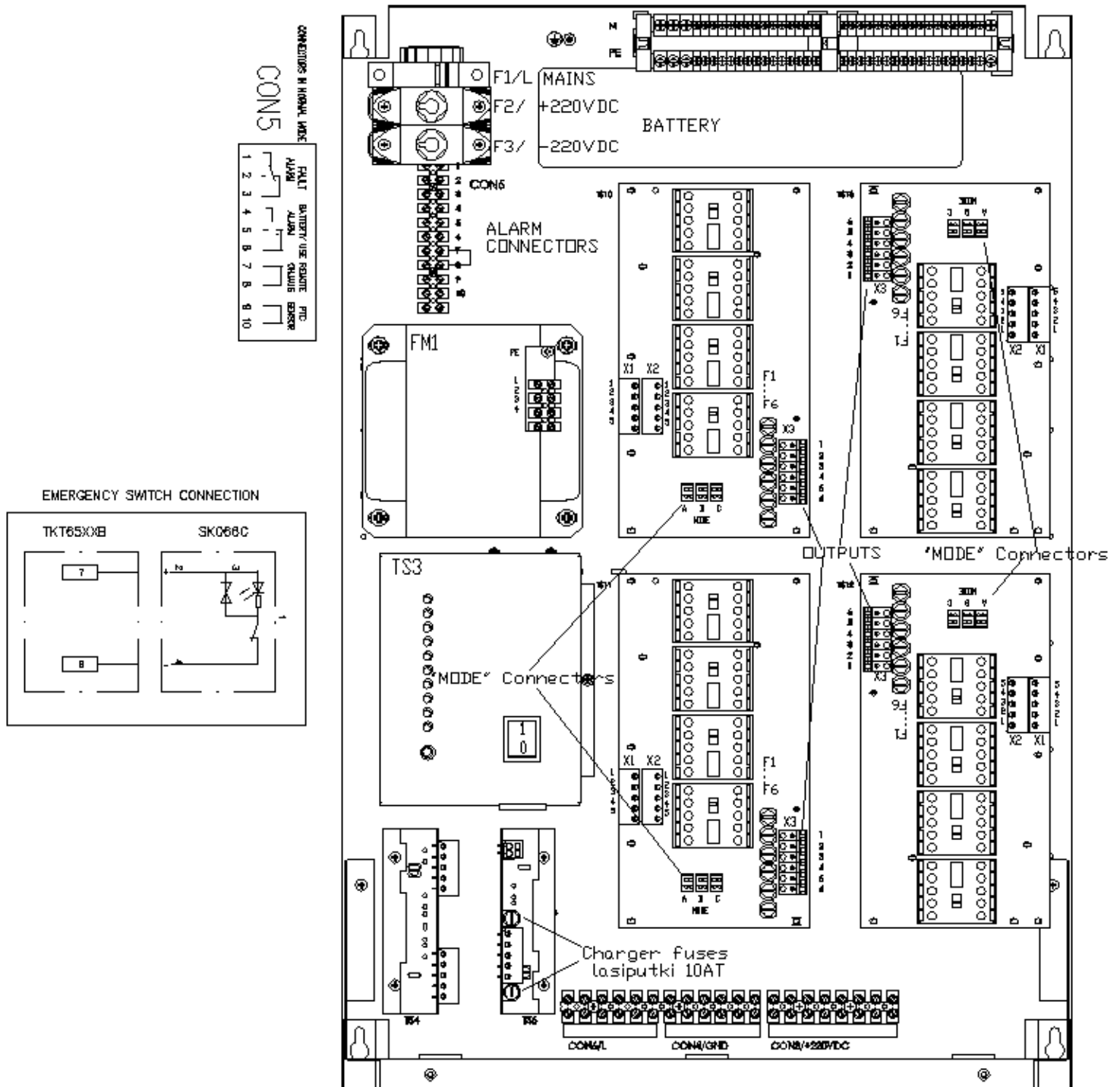

APPENDIX 3

Part placement

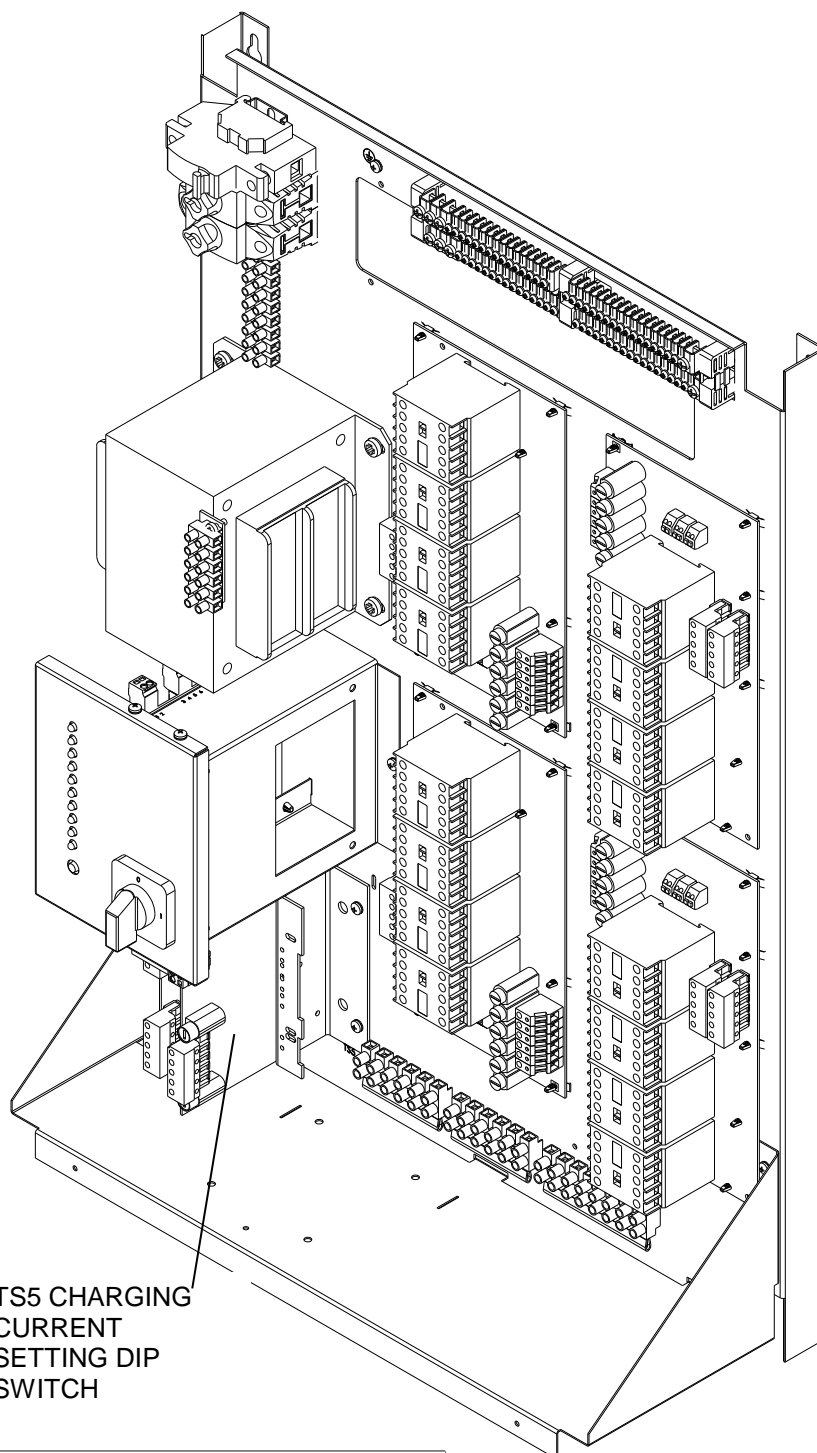

AKKU/Ah	38	24	17	7
ALL OFF = 65Ah	<input type="checkbox"/>	<input type="checkbox"/>	<input type="checkbox"/>	<input type="checkbox"/>
XST0201 ON	<input type="checkbox"/>	<input type="checkbox"/>	<input checked="" type="checkbox"/>	<input type="checkbox"/>



Teknoware Oy, Ilmarisentie 8, 15200 LAHTI, puh. (03) 883 020, fax (03) 8830 260
www.teknoware.fi e-mail: emexit@teknoware.fi

APPENDIX 4

Dimensions (TKT65...B)

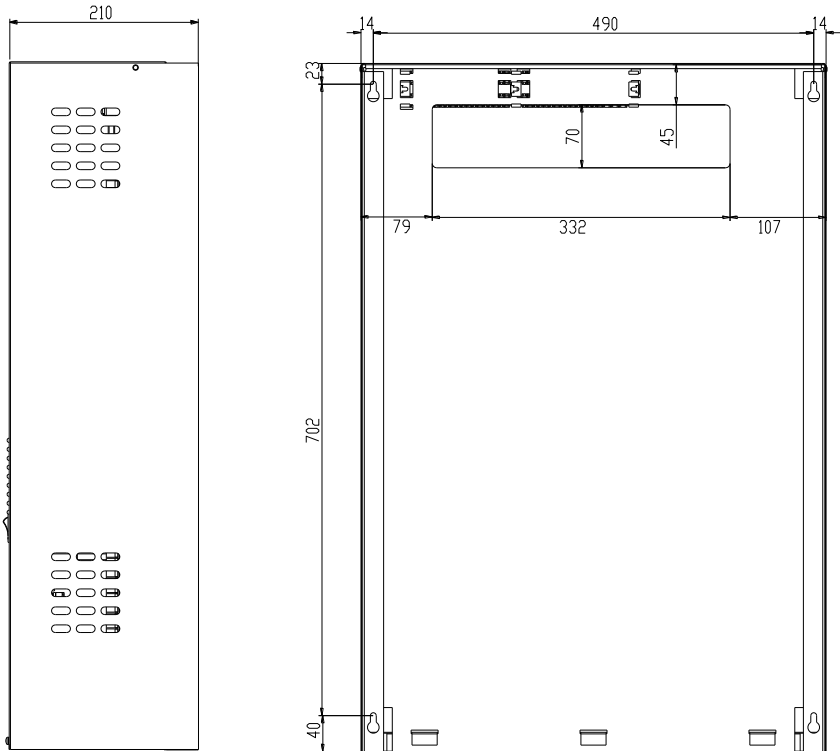
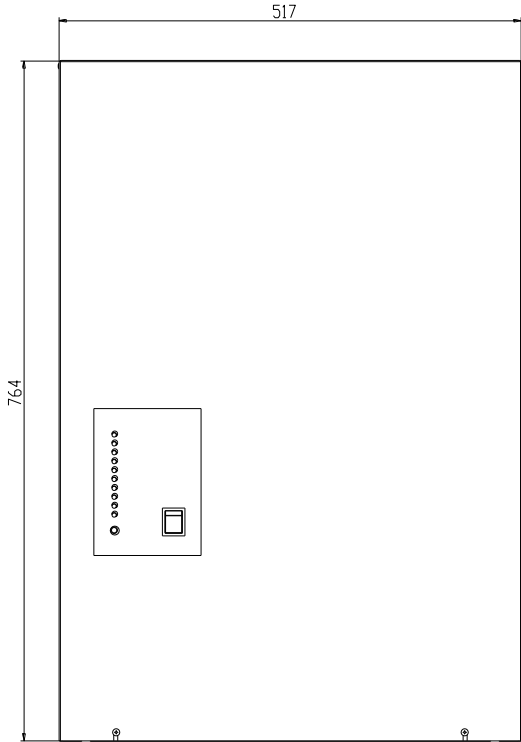

Teknoware Oy, Ilmarisentie 8, 15200 LAHTI, puh. (03) 883 020, fax (03) 8830 260
www.teknoware.fi e-mail: emexit@teknoware.fi

APPENDIX 4

Dimensions (TKT65xxBP, cabinet construction)

