

TKT7Series

Addressable 230 V Central Battery Systems

User's Guide

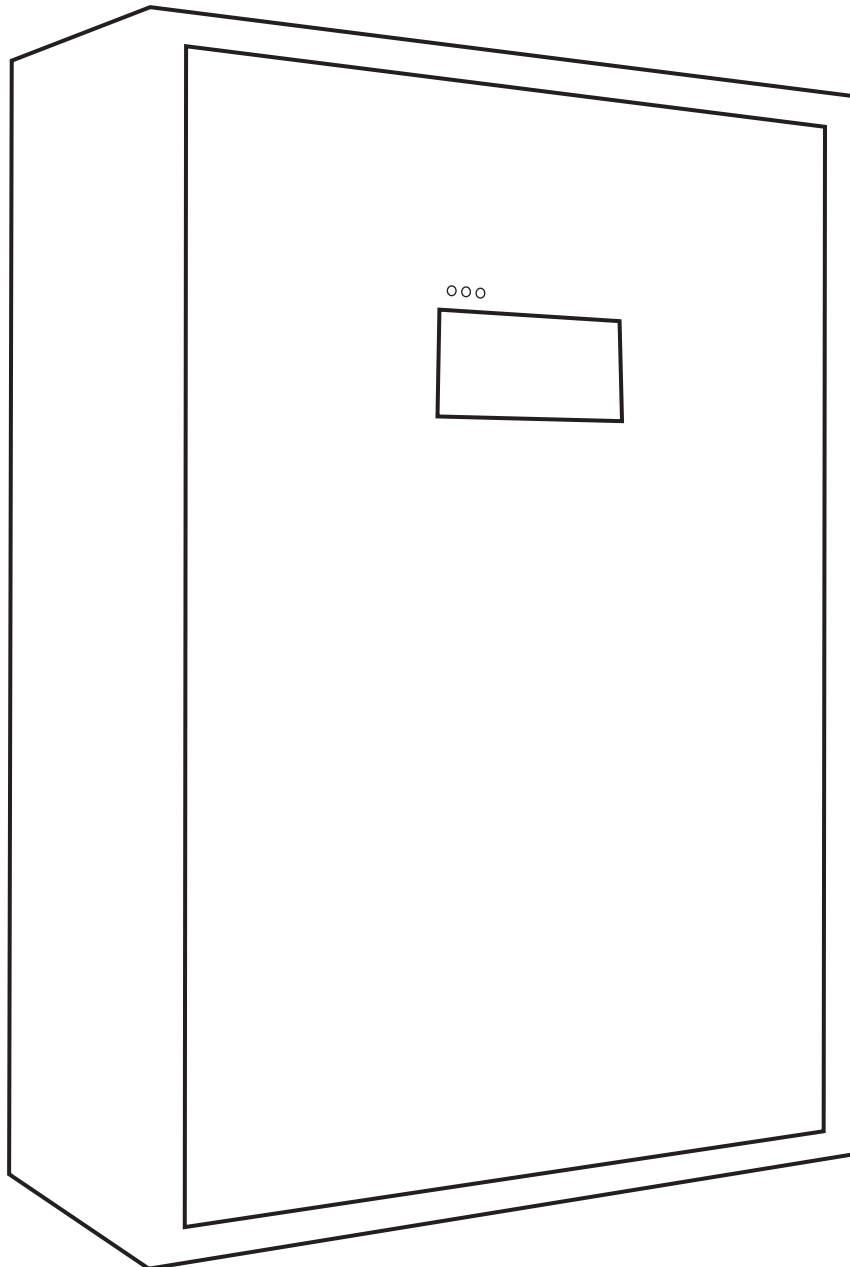



The central battery unit and the battery housing can be opened only by a qualified electrician. Only a qualified electrician can do maintenance or installing tasks.

Setting only the input fuse to 0-position will NOT make the central battery unit de-energized.

Device must be made de-energized before any maintenance or repair work: set the input fuse and the battery fuses to 0-positions.



Green LED lit: Mains present, central battery unit in mains mode (AC)

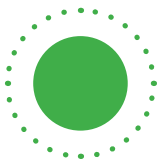

Green LED blinking: Mains present, central battery unit in battery mode (DC), for example during the battery test



Yellow LED lit: Central battery unit in battery mode (DC)



Red LED lit: Internal / external error

Table of Contents

1.	Product Description	4
1.1	Manufacturer	4
1.2	Type	4
1.3	General Description	4
1.4	Storage	4
2.	Planning the System	5
3.	Installing the System	5
4.	Parts and Layout	6
4.1	TKT75/76/78	6
4.2	TKT77	7
4.3	Data Connections (USB, Ethernet)	8
5.	Commissioning	8
6.	Main View	9
6.1	Setting system time	9
6.2	Show Main CBU Status	10
6.3	Show External Status	10
6.4	Status: Batteries	10
7.	Settings	11
7.1	Adding and Modifying User Profiles	11
7.2	Automatic Testing	12
7.3	Battery Settings	12
7.4	Network Settings	12
8.	Devices	13
9.	Test Settings and Logs	13
10.	Updating the System Software	14
11.	Technical details	14
12.	Mechanical Dimensions: TKT75/76	17
13.	Mechanical Dimensions: TKT77	18
14.	Mechanical Dimensions: TKT78	19
15.	Connections	20
15.1	Interfaces	20
16.	Connection alternatives for batteries	21

1. Product Description

1.1 Manufacturer

Teknoware Oy
PL 19, FI-15101 Lahti
Ilmarisentie 8, FI-15200 Lahti

1.2 Type

TKT75...C

TKT76...C

TKT77...C

TKT78...C

1.3 General Description

TKT7 Series consists of addressable 230 V central battery units (=CBU) for emergency lighting. In a normal situation, the central battery unit operates using a 230 V AC mains voltage, maintaining the battery charge level and supplying a voltage of 230 VAC to the output circuits. If the mains voltage is interrupted, the central battery unit switches to battery use. This connects a voltage of 216 VDC to the emergency light circuits. The battery supply is used as long as the mains voltage remains unavailable or the battery voltage has dropped to the low discharge limit.

In addition to the above mentioned standard functions, the control unit of the central battery unit also includes the following monitoring, testing and reporting functions:

- Testing the luminaires automatically, monitoring their operation, and indicating faulty luminaires addresses'.
- Testing the batteries automatically.
- All tests can be activated also manually.
- A learning system; luminaires can be added and removed after commissioning.
- Status- and error warnings via relay connections to building management systems.
- A direct data connection to Teknoware's ACM systems.
- All functions available from the touch screen user interface.

1.4 Storage

If the CBU and batteries are not installed upon delivery, please note the following things:

- Store the unit in a dry place, protected from humidity.
- Store the unit and the batteries in the recommended storing temperature of +10...+30°C.
- If the batteries are stored for a longer period of time, they must be recharged every six months for at least 12 hours at a time.

Note!

The delivery may include lead acid batteries, that have charge, and that may short circuit due to improper storage! Take this into account when storing the CBU.

2. Planning the System

In Teknoware TKT7 Series system the monitoring data between the CBU and the luminaires is transferred via the circuit cables. There is no need for separate data cabling, and the supply cables can be drawn as any emergency lighting cabling would be. The following, however, must be taken into account:

- All luminaires must be addressable Teknoware 230 V luminaires. These luminaires contain the necessary electronics for the communication between the CBU and the luminaires.

Each of the luminaires within a circuit must have an individual address. (1..32). Addresses can be chosen freely, as long as there are no overlapping addresses within a circuit. The addresses are marked to the included label according to electrical planning (circuit nr. / luminaire nr.). Additional information about setting the address can be found from the documents delivered with the luminaires.

3. Installing the System

1. TKT75/76: attach the CBU firmly to a wall (there are four attachment points)
2. TKT77/TKT78: set the CBU to an even sturdy surface against a wall
3. Open the CBU door.
4. Make sure that the input fuse and the battery fuses are in 0 positions.
5. Connect the circuits and additional devices. Connections and interfaces are listed at the end of this Guide.
6. Place the temperature sensor between the batteries. Note that misplacing the temperature sensor may damage the batteries!
7. Connect the batteries in series (check the polarity and insulation distances). Start from the furthest battery (looking from the battery fuse), and connect the battery connected to the battery fuse last.
8. Connect the CBU to mains.
9. Turn the battery fuses to 1 position.
10. Turn the input fuse to 1 position
11. Check the batteries and connections for short circuits.
12. Close and lock the CBU door.
13. The CBU is ready for commissioning

4. Parts and Layout

4.1 TKT75/76/78

Note! TKT78 models have an integrated battery cabinet, and no wall mounting tabs.

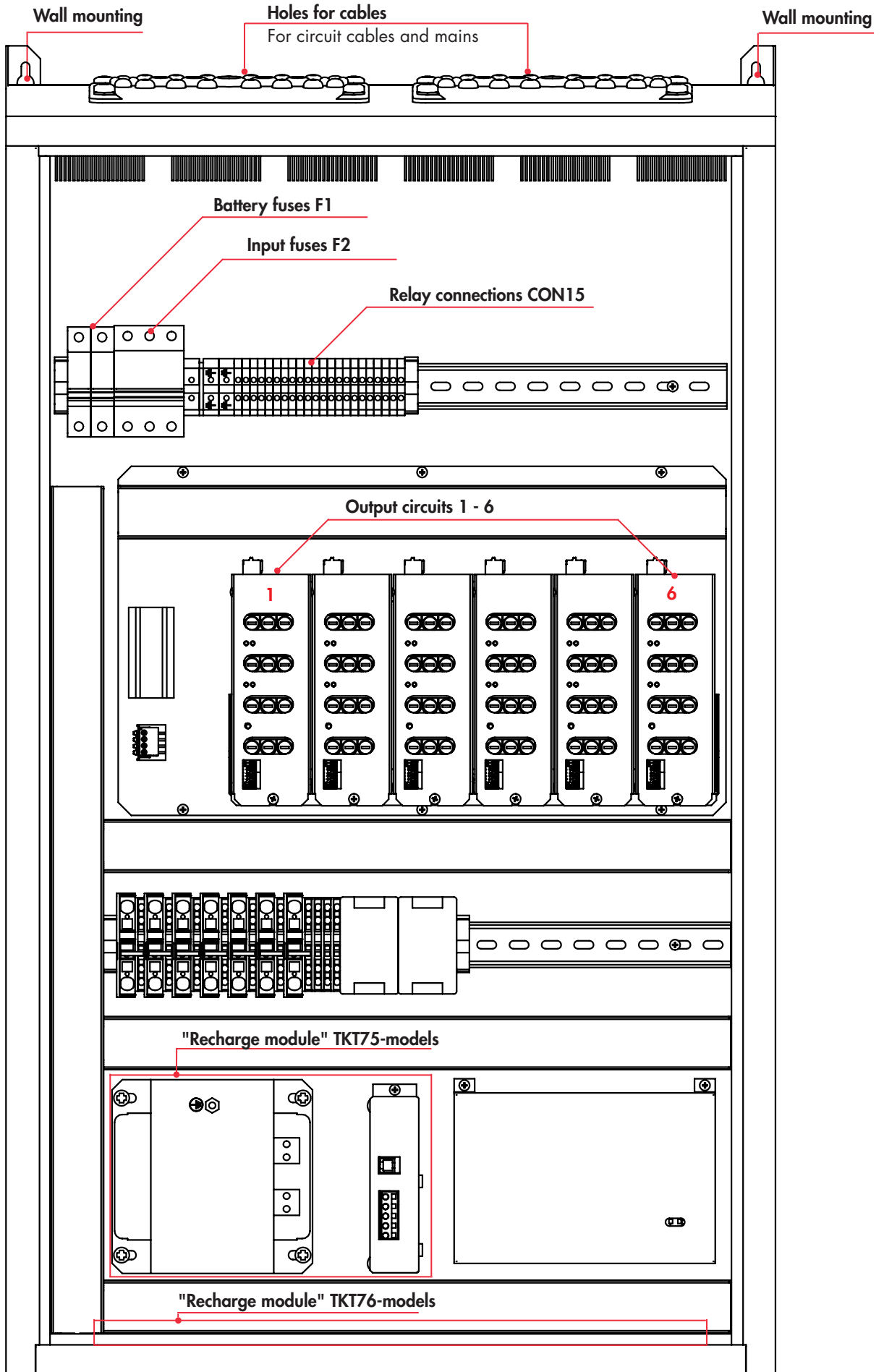

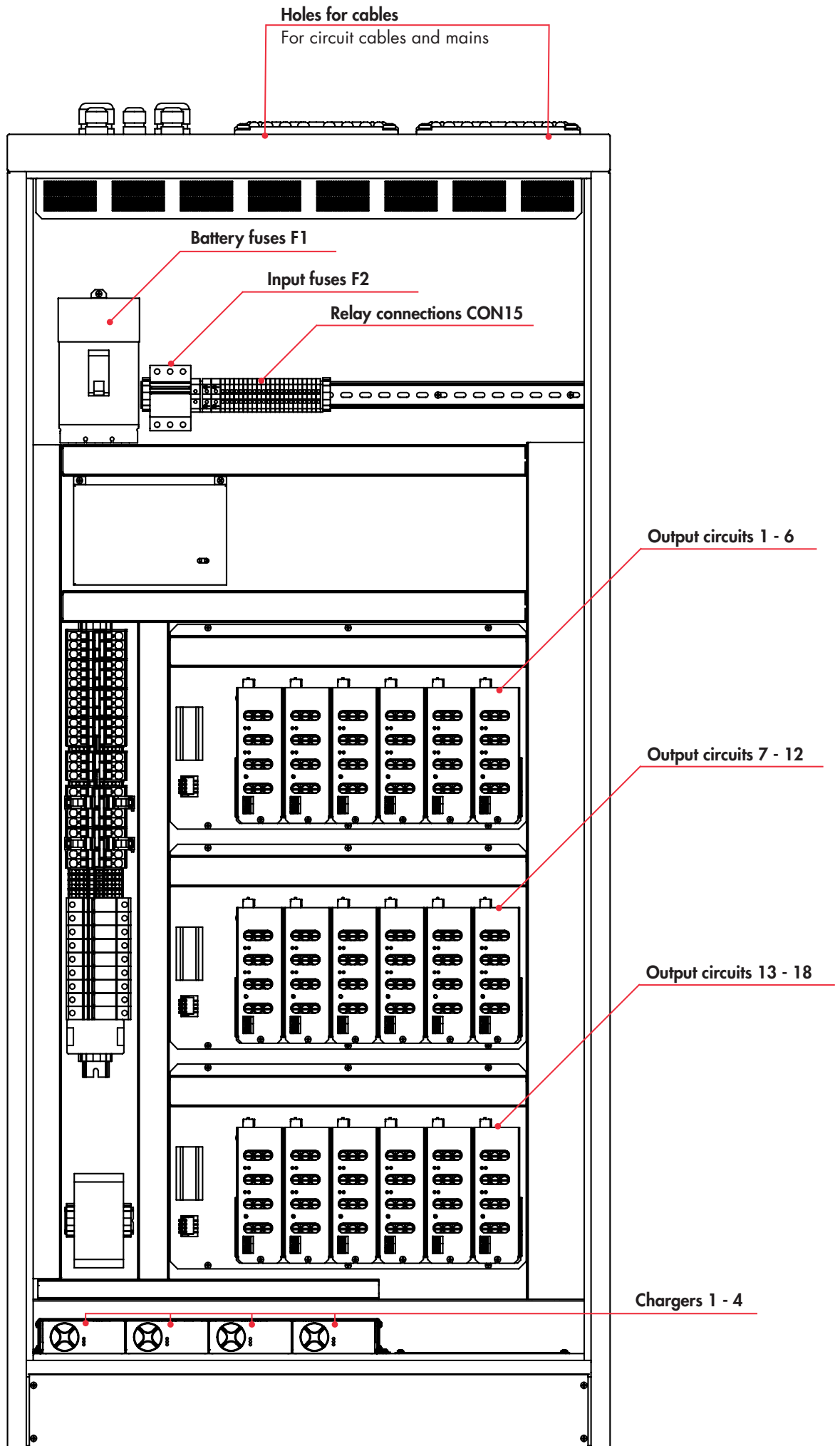

4.3 Data Connections (USB, Ethernet)

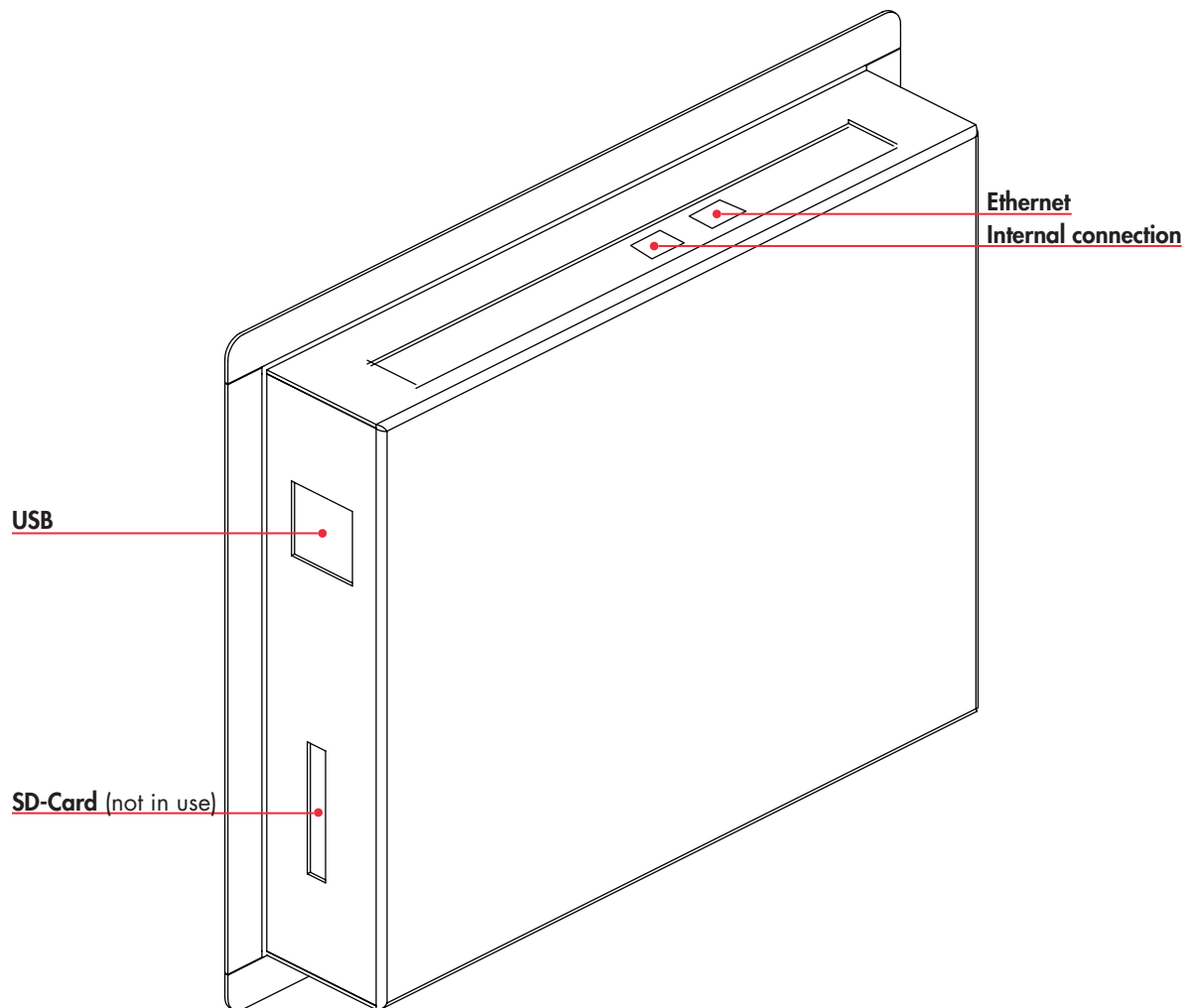

5. Commissioning

Process description:

1. Set the system time – see *Chapter 6.1 Settings System Time*.
2. Configure the battery settings – see *Chapter 7.3 Battery Settings*.
3. Configure the test settings – see *Chapter 7.2 Automatic Testing*.
4. Optional: Configure internet settings for MyTeknoware, WebCM/ACM and direct connection – see *Chapter 7.4 Network Settings*.
5. Recommended: Change the Administrator password, and set up user accounts – see *Chapter 7.1 Adding and Modifying User Profiles*.
6. Get the luminaire configuration – see *Chapter 7 Settings*.
7. Recommended: Create a database backup – see *Chapter 7 Settings*.

Re-configuring the luminaire setup

If the emergency lighting system is changed (luminaires added or removed) after commissioning, the luminaire configuration must be made again. The system compares the luminaire test results to an existing database, so for example, changes in the amount of luminaires might result in unnecessary luminaire error notifications.

6. Main View

- Displayed without a password.
- **System status:** States the system status: OK/error (if there are errors in the system they are displayed here). Note that the **Deep discharge** error is displayed separately.
- **Operation status:** AC=mains / DC=battery operation.
- **Mains voltage**
- **Battery voltage**
- **Battery current**
- **Upper right corner:** Login to system/ user name.

Teknoware TKT7624CP
Name: Administrator: O
System status: **OK**

Operation status: AC mode
Mains voltage: ON
Battery voltage: 0.0 V
Battery current: 0.0 A
Charging mode: Not initialized
Running test: None

External device status: **OK**

Buttons: Show Internal Errors ->, Show Main CBU Status, Show Sub CBU Status, Show Battery Status, Show External Status ->

Bottom bar: HOME, DEVICES, TEST, SETTINGS, 13:04 2020 Apr 28

After login:

- **Show Internal Errors:** If there are internal errors in the system, tapping this button list the errors with details
- **Show Main CBU Status**
- **Show Battery Status**
- **Show External Status:** Displays circuit- and luminaire statuses. If there are external errors in the system, tapping this button will show a summary of the errors, and options to view the faulty luminaires/ circuits.

Teknoware TKT7624CP
Name: Administrator: O
System status: **1 System error**

Operation status: AC mode
Mains voltage: ON
Battery voltage: 0.0 V
Battery current: 0.0 A
Charging mode: Not initialized
Running test: None

External device status: **OK**

Buttons: Show Internal Errors ->, Show Main CBU Status, Show Sub CBU Status, Show Battery Status, Show External Status ->

Bottom bar: HOME, DEVICES, TEST, SETTINGS, 13:14 2020 Apr 28

	Device	Defect type	Time	
CONFIRM	Central unit	Over a year since last battery test	2019-01-04 09:45	<
CONFIRM	Master IO	Charge ripple too high	2019-01-01 10:10	

Bottom bar: HOME, DEVICES, TEST, SETTINGS, 14:19 2020 Apr 28

6.1 Setting system time

To set/change the system time, log in as an administrator, tap the time/date box on the lower right corner of the screen, and type in the correct time and date.

Set date and time

Date: 18. Nov 2019

Time: 14 : 04

Zone: 3 : 0

Buttons: SAVE, CANCEL

6.2 Show Main CBU Status

- **To DC Mode -button:** Switches the CBU to DC mode (note that all emergency lights are lit!). Returns to AC automatically in 5 minutes.
- **Show Sub CBU Status**
- **Show Battery Status**
- **Operation status:** AC or DC mode.
- **Event Log:** Opens the event log (see image)

6.3 Show External Status

- **Circuits:** the number of circuits in the system.
 - Show 1st Faulty: If there are errors present, this function opens the Extern Devices view, with a focus on the first circuit with errors.
- **Luminaires:** the amount of luminaires in the system
 - Show 1st Faulty: If there are errors present, this function opens the External Devices/ luminaire details view, displaying details about the first luminaire with an error.
- **Intelligent controller:** the number of Intelligent Controller control units in the system.

6.4 Status: Batteries

- **Battery voltage**
- **Battery current**
- **Charging:** Charge mode.
- **Battery size**
- **Backup power duration**

7. Settings

- **User Profiles:** Add and edit user accounts.
- **Start configuration:** Start the automatic luminaire configuration. Do this when commissioning the CBU for the first time, and when the luminaire setup has changed.
- **Load IC-Conf:** Load Intelligent Controller -configuration to CBU.
- **Send IC-Conf:** Send Intelligent Controller -configuration to IC controller.
- **Save IC-Conf:** Save current Intelligent Controller -configuration to the USB drive.
- **Automatic test:** Automatic test settings.
- **Battery settings**
- **Create DB backup:** Create a backup of the CBU database to a USB drive. The database contains all settings, including user-profiles and circuit/luminaire data. To create a database, insert a USB drive to the USB port, tap Create DB backup button, and follow the instructions on the screen.
- **Load DB backup:** Load a previously saved CBU backup database from a USB drive.
- **Network settings.**
- **Device settings:** From here you can name the CBU, and change the operating system's language. Simply make the changes, and tap "UPDATE AND SAVE". Note that the "Command" function is reserved only for authorized maintenance work.

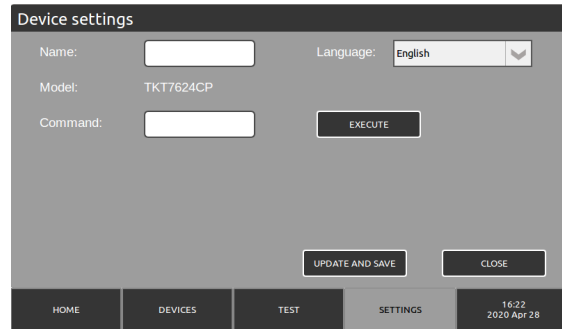
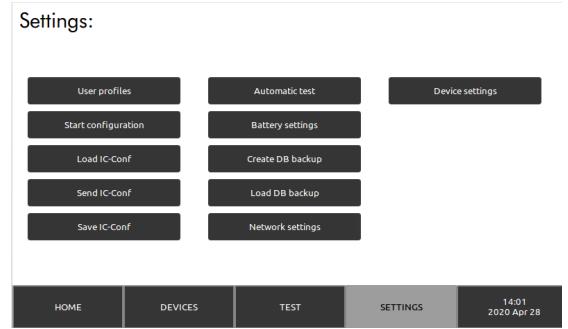

7.1 Adding and Modifying User Profiles

Settings > User Profiles

- On the left side, there is a list of the existing user profiles in the system.
- To add a user to the system, first log in as Administrator. Then, from the User profiles view, tap "NEW". Type in the User name and the password for this user. Type the password again in the Password confirmation box. Select a user level from the drop-down menu:
 - Basic user can view error notifications and system status
 - Advanced user can also start tests and view test logs
 - The administrator has unlimited access to change CBU settings and create new user profiles.
- You can modify user settings by selecting a user from the Users list, and tapping "EDIT". To remove a user, select the user from the list and tap "REMOVE".

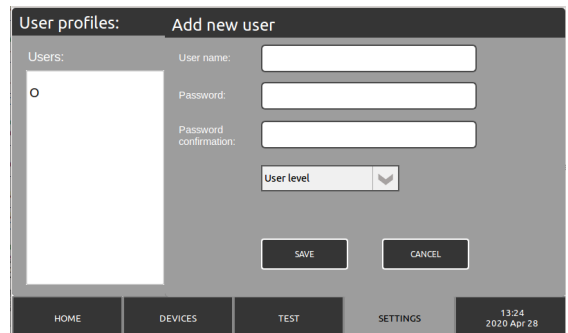
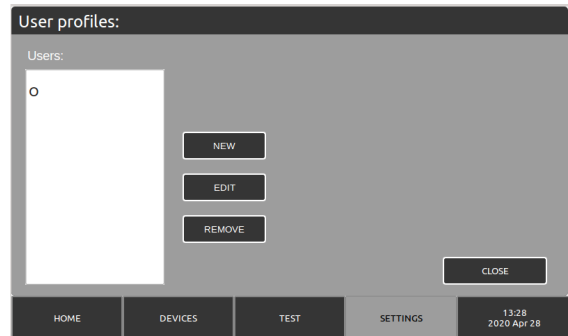

7.2 Automatic Testing

Settings > Automatic tests

- Duration test occurs: set the time interval for duration test and the time for running the test. Preferred time for the test is a time when the building is as empty as possible. For example, an office building might be empty during a national holiday, at night time.
- Luminaire test occurs: set the time interval for the luminaire test, and the time for running the test. Note that the luminaires may blink during the test.

Automatic tests

Duration test occurs: Every 6th month CHANGE
1st Week
Monday
at: 06 : 00
Next test: 2020-10-05 at 06:00

Luminaire test occurs: Every 2nd day CHANGE
at: 06 : 00
Next test: 2020-04-30 at 06:00

ENABLING TESTS

UPDATE AND SAVE CLOSE

HOME DEVICES TEST SETTINGS 13:29 2020 Apr 28

7.3 Battery Settings

Settings > Battery settings

- These are correct by default.
- Note: do not change these settings unless you know what you are doing.

Battery settings

Battery type: NICD Battery capacity: 90 Ah
Under Voltage: 227.0 V Over Voltage: 255.0 V
Load-off voltage: 184.0 V Shut-down voltage: 173.0 V
External charger: YES Serial number: 563241121
Checktime: 10 min Voltage drop: 3.0 V

Reboot required

RESET UPDATE AND SAVE CLOSE

HOME DEVICES TEST SETTINGS 13:35 2020 Apr 28

Battery settings

Battery type: NICD Battery capacity: 90 Ah
Under Voltage: 227.0 V Over Voltage: 255.0 V
Load-off voltage: 184.0 V Shut-down voltage: 173.0 V
External charger: NO Charging voltage: 243 V
Operation time: 9 h Voltage limit: 212.0 V

RESET UPDATE AND SAVE CLOSE

HOME DEVICES TEST SETTINGS 13:36 2020 Apr 28

7.4 Network Settings

Settings > Network settings

Contains the network settings of the CBU. These are used for direct connection, WebACM/CM connections, and MyTeknoware connections.

- **Device name**
- **IP address**
- **Netmask**
- **Gateway**
- **Dns-ip**
- **DHCP**
- **Enable Cloud:** check this box, and tap the Load certification button to load a cloud connection certificate to connect to MyTeknoware.

Network settings

IP address: 172.22.9.180 MAC:00:0C:29:BB:DD:DA
Netmask: 255.255.255.0 Load certificates
Gateway: 172.22.9.1 Enable Cloud:
Dns-ip: Cloud Verbose:
DHCP:

UPDATE AND SAVE CLOSE

HOME DEVICES TEST SETTINGS 14:02 2020 Apr 28

8. Devices

- **Circuit:** Output circuit, 1-4 circuits / module
- **Main view:** The luminaires connected to the selected circuit board. Green squares are luminaires that are functioning correctly. Red squares are luminaires that have reported an error. NM=Non Maintained (emergency luminaire), M=Maintained (exit luminaire), ND=Not Defined.
- Tapping a luminaire square displays details about the luminaire. You can also add notes to the luminaire from this view.
- I.C. Overview: An overview of optional Teknoware Intelligent Controller system.
- Test Circuit: Tests the selected circuit.
- Show only faulty: Display only the faulty luminaires/circuits.

Luminaires Overview: TKT7624CP

Luminaire Status:

9. Test Settings and Logs

- **Start battery test:** Runs a battery test for 2/3 of the set duration.
- **Start a full battery test:** Runs a battery test for the full duration.
- **Start complete luminaire test:** Tests all luminaires in the system.
- **Start faulty only:** Start a test for luminaires that have reported an error.

- **Battery test history:** A log of previously ran battery tests. Show ERROR option shows only tests that reported an error. "CBU" indicates the number of the CBU, "Test done" when the test was run, "Duration" how many minutes the test lasted, "Voltage After" the battery voltage after the test, and "Result" whether the test found any errors (OK/ERROR).

#	CBU	Test done	Duration	Voltage after	Result
51	1	09/03/2020 16:45	0	0.0	ERROR
50	1	07/10/2019 09:56	1385	218.3	ERROR
49	1	26/07/2019 08:58	1586	210.7	OK
48	1	14/05/2019 08:01	1667	212.4	ERROR
47	1	02/03/2019 06:03	1113	212.0	ERROR
46	1	19/12/2018 05:06	1348	211.6	ERROR
45	1	07/10/2018 05:08	1715	218.0	ERROR
44	1	26/07/2018 04:10	1080	213.1	ERROR

Show ERROR

- **Luminaire test history:** A log of previously ran luminaire tests. "Result" indicates whether the test found any errors, and "SHOW" button displays details about the test.

Result	Circuits	Test done	Info
OK	All	20/12/2009 09:54	SHOW
ERROR	All	19/12/2009 09:54	SHOW

1/1

Filter Export

10. Updating the System Software

To update the TKT7 system software:

1. Make sure the update files are on the root folder of a USB drive. There should be no other files on the drive.
2. It is recommended that you create a database backup before updating the system.
3. De-energize the CBU.
4. Insert the USB drive to the USB port.
5. Energize the CBU, and follow the instructions on the screen.

Note!

Do not remove the USB drive, or de-energize the CBU during update!

11. Technical details

Default voltage limits

- When mains drops below 180 VAC, the CBU supplies voltage for the emergency lighting from the batteries.
- If the battery voltage rises above 255 V, the CBU gives a Battery Overvoltage warning.
- If the battery voltage drops below 227 V, the CBU gives a Battery Undervoltage warning.
- During battery mode, if the battery voltage drops below 173 V, the CBU goes into deep discharge mode.

Casing / IP Class	IP31
Max. relative humidity:	95%
Ambient Temperature:	+10...+30°C
Output Voltage:	Main supply: 220-240 VAC, Battery supply: 216 VDC
Battery Voltage:	216 VDC (18 x 12V Pb / 180 x 1,2V NiCD)
Battery Recharge Time:	12 h (80 %)
Output Connector:	max. wire 4 mm ²
Mass (without batteries):	TKT75: max 61 kg TKT76: max 50 kg TKT77: max 110 kg TKT78: max 145 kg

Model	CBU Input Fuse:	Battery fuse:
TKT75/7804CFP	3-phase circuit breaker 16 A C-curve	circuit breaker 16 A
TKT75/7804CP	1-phase circuit breaker 16 A C-curve	circuit breaker 10 A
TKT75/7808CFP	3-phase circuit breaker 16 A C-curve	circuit breaker 16 A
TKT75/7808CP	1-phase circuit breaker 16 A C-curve	circuit breaker 16 A
TKT75/7816CFP	3-phase circuit breaker 16 A C-curve	circuit breaker 32 A
TKT75/7816CP	1-phase circuit breaker 16 A C-curve	circuit breaker 32 A
TKT75/7824CFP	3-phase circuit breaker 32 A C-curve	circuit breaker 32 A
TKT75/7824CP	1-phase circuit breaker 16 A C-curve	circuit breaker 32 A
TKT7604CFP	3-phase circuit breaker 16 A C-curve	circuit breaker 16 A
TKT7608CFP	3-phase circuit breaker 16 A C-curve	circuit breaker 16 A
TKT7616CFP	3-phase circuit breaker 32 A C-curve	circuit breaker 32 A
TKT7624CFP	3-phase circuit breaker 32 A C-curve	circuit breaker 63 A
TKT7724-72CP	3-phase circuit breaker 50 A C-curve	circuit breaker 160 A

Output circuit fuses: 5x20 mm sand-filled glass tube fuse 2,5 A

Product Code	Nominal Supply Voltage	Max Battery Capacity (Ah)	Max total load, mains operation (VA)	Max total load, battery operation 1h (W)	Max total load, battery operation 3h (W)	Circuits
TKT7504CFP	3~ N/PE 220-240/380-415 VAC, 50/60 Hz	65	1400	1400	1400	4
TKT7504CP	1~ N/PE 220-240 VAC, 50/60 Hz	65	1400	1400	1400	4
TKT7508CFP	3~ N/PE 220-240/380-415 VAC, 50/60 Hz	65	2800	2800	2800	8
TKT7508CP	1~ N/PE 220-240 VAC, 50/60 Hz	65	2580	2800	2800	8
TKT7516CFP	3~ N/PE 220-240/380-415 VAC, 50/60 Hz	65	5600	5600	3340	16
TKT7516CP	1~ N/PE 220-240 VAC, 50/60 Hz	65	2580	5600	3340	16
TKT7524CFP	3~ N/PE 220-240/380-415 VAC, 50/60 Hz	65	8400	6000	3340	24
TKT7524CP	1~ N/PE 220-240 VAC, 50/60 Hz	65	2580	6000	3340	24
TKT7604CFP	3~ N/PE 220-240/380-415 VAC, 50/60 Hz	150	1400	1400	1400	4
TKT7608CFP	3~ N/PE 220-240/380-415 VAC, 50/60 Hz	150	2800	2800	2800	8
TKT7616CFP	3~ N/PE 220-240/380-415 VAC, 50/60 Hz	150	5600	5600	5600	16
TKT7624CFP	3~ N/PE 220-240/380-415 VAC, 50/60 Hz	150	8400	8400	7580	24
TKT7724CP	3~ N/PE 220-240/380-415 VAC, 50/60 Hz	450	8400	8400	8400	24
TKT7732CP	3~ N/PE 220-240/380-415 VAC, 50/60 Hz	450	11200	11200	11200	32
TKT7740CP	3~ N/PE 220-240/380-415 VAC, 50/60 Hz	450	14000	14000	14000	40
TKT7748CP	3~ N/PE 220-240/380-415 VAC, 50/60 Hz	450	16800	16800	16800	48
TKT7756CP	3~ N/PE 220-240/380-415 VAC, 50/60 Hz	450	19600	19600	19600	56
TKT7764CP	3~ N/PE 220-240/380-415 VAC, 50/60 Hz	450	22400	22400	22400	64
TKT7772CP	3~ N/PE 220-240/380-415 VAC, 50/60 Hz	450	25200	25200	22740	72

Product Code	Nominal Supply Voltage	Max Battery Capacity (Ah)	Max total load, mains operation (VA)	Max total load, battery operation 1h (W)	Max total load, battery operation 3h (W)	Circuits
TKT7804CFP	3~ N/PE 220-240/380-415 VAC, 50/60Hz	65	1400	1400	1400	4
TKT7804CP	1~ N/PE 220-2240 VAC, 50/60Hz	65	1400	1400	1400	4
TKT7808CFP	3~ N/PE 220-240/380-415 VAC, 50/60Hz	65	2800	2800	2800	8
TKT7808CP	1~ N/PE 220-2240 VAC, 50/60Hz	65	2580	2800	2800	8
TKT7816CFP	3~ N/PE 220-240/380-415 VAC, 50/60Hz	65	5600	5600	3340	16
TKT7816CP	1~ N/PE 220-2240 VAC, 50/60Hz	65	2580	5600	3340	16
TKT7824CFP	3~ N/PE 220-240/380-415 VAC, 50/60Hz	65	8400	6000	3340	24
TKT7824CP	1~ N/PE 220-2240 VAC, 50/60Hz	65	2580	6000	3340	24

12. Mechanical Dimensions: TKT75/76

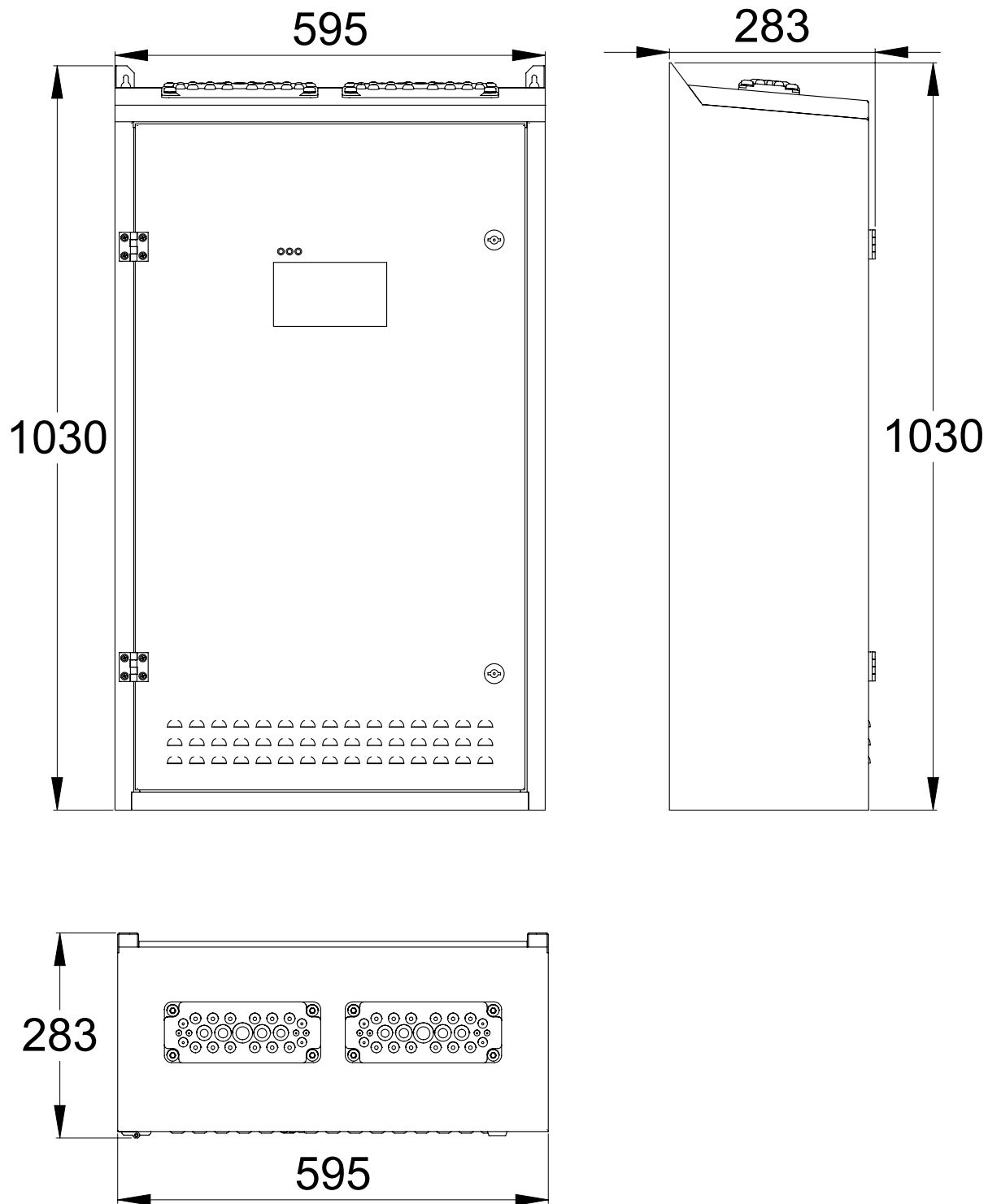

13. Mechanical Dimensions: TKT77

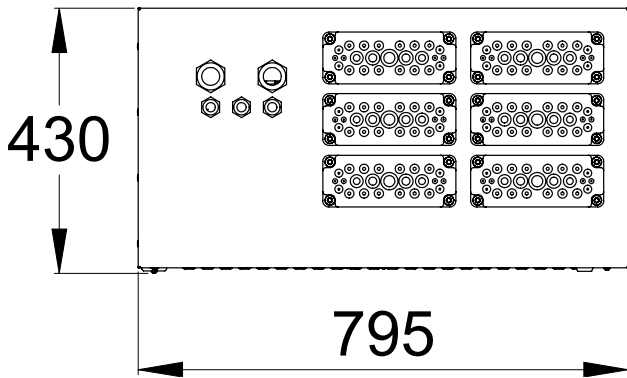
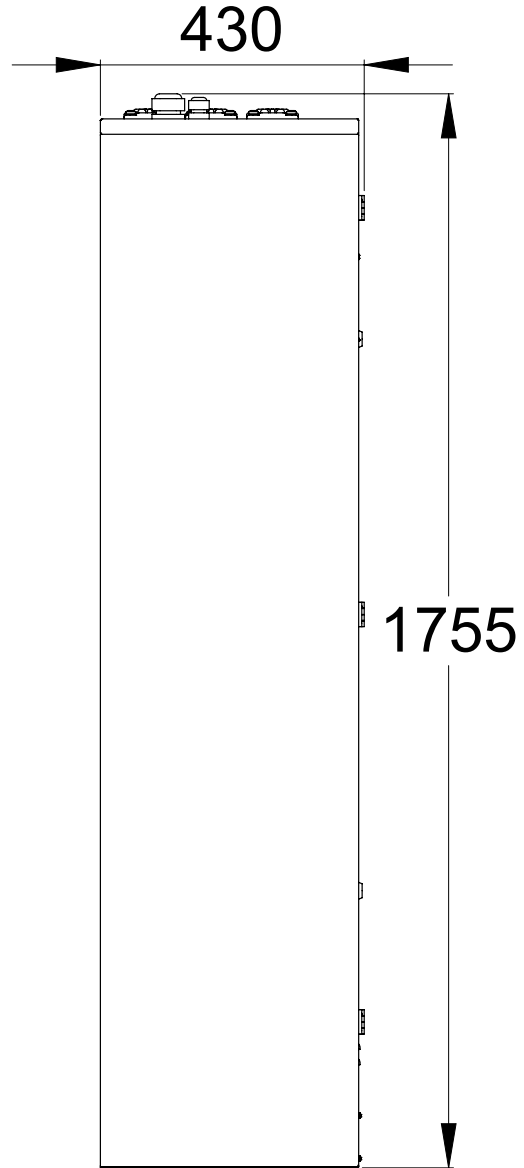
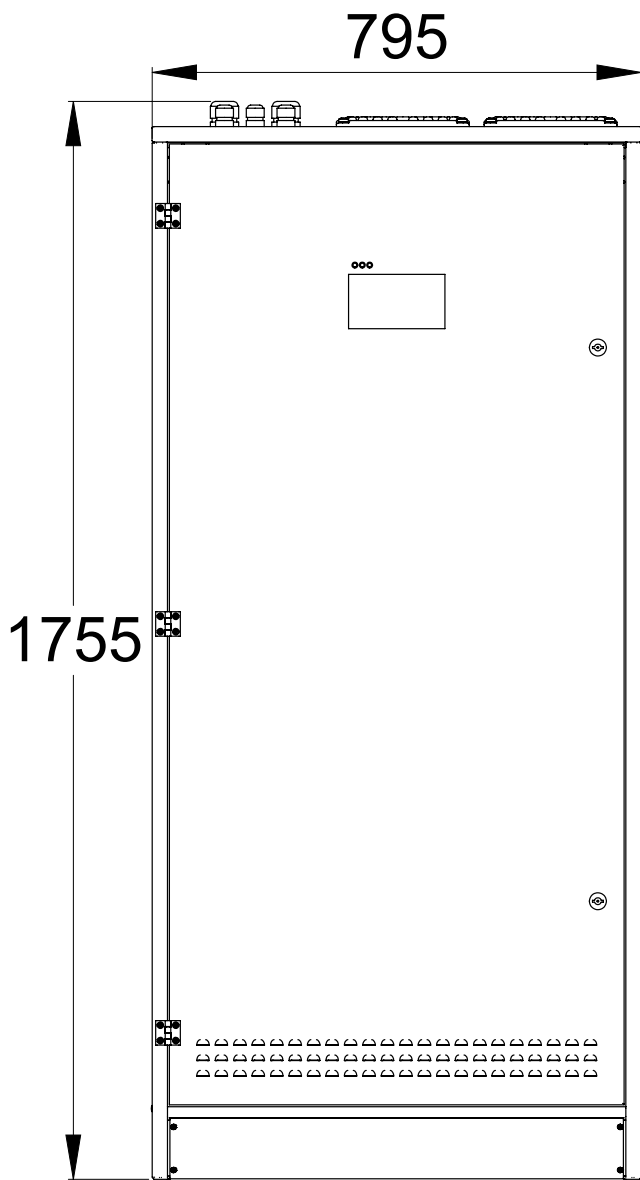

14. Mechanical Dimensions: TKT78

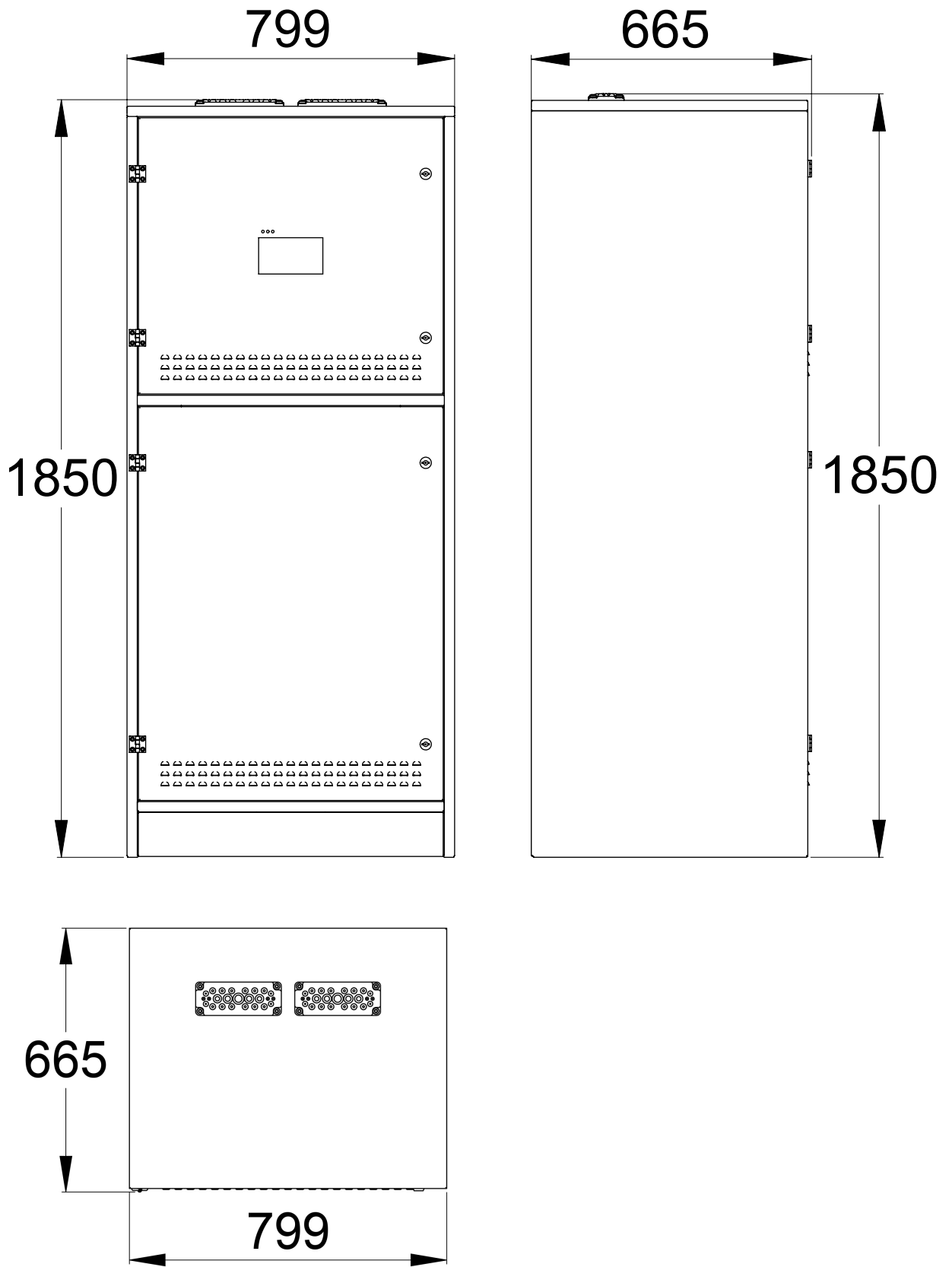

15. Connections

15.1 Interfaces

1-2	REMOTE CONTROL INPUT (BATTERY MODE)
3-4	REMOTE CONTROL FOR LUMINAIRES WITH LOCAL CONTROLLER FUNCTION INPUT
5-6	EMPTY
7-9	FAULT ACTIVE OUTPUT
10-12	BATTERY MODE ACTIVE OUTPUT
13-15	SYSTEM IN OPERATION OUTPUT
16-18	RS232 INTERFACE (BACNET)
19-20	RS485 INTERFACE (ACM)
21-22	TEMPERATURE SENSOR
23 (+) - 24 (-)	IC-INTERFACE (OPTIONAL)

16. Connection alternatives for batteries

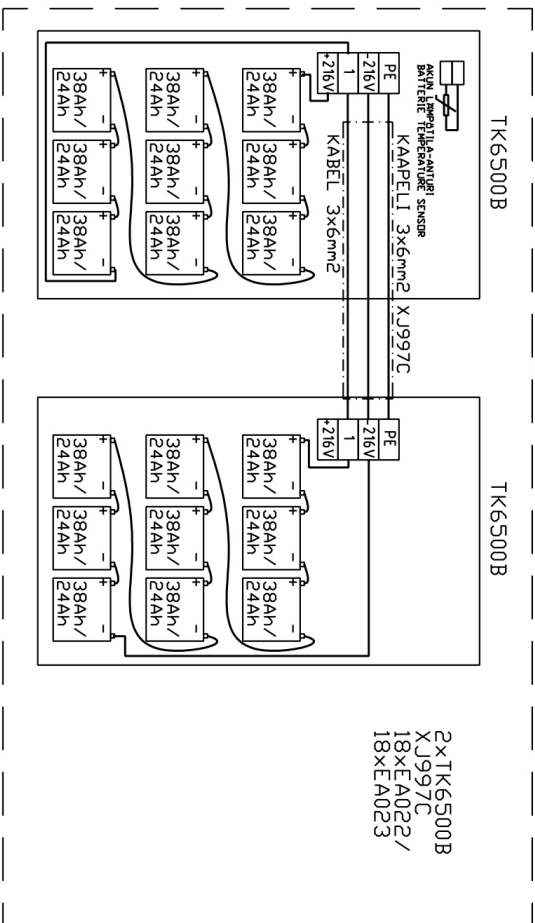
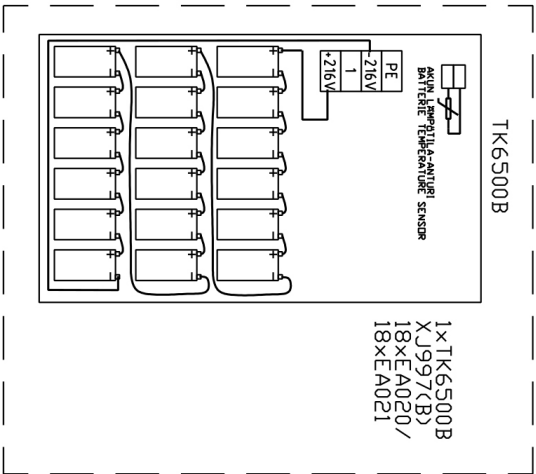
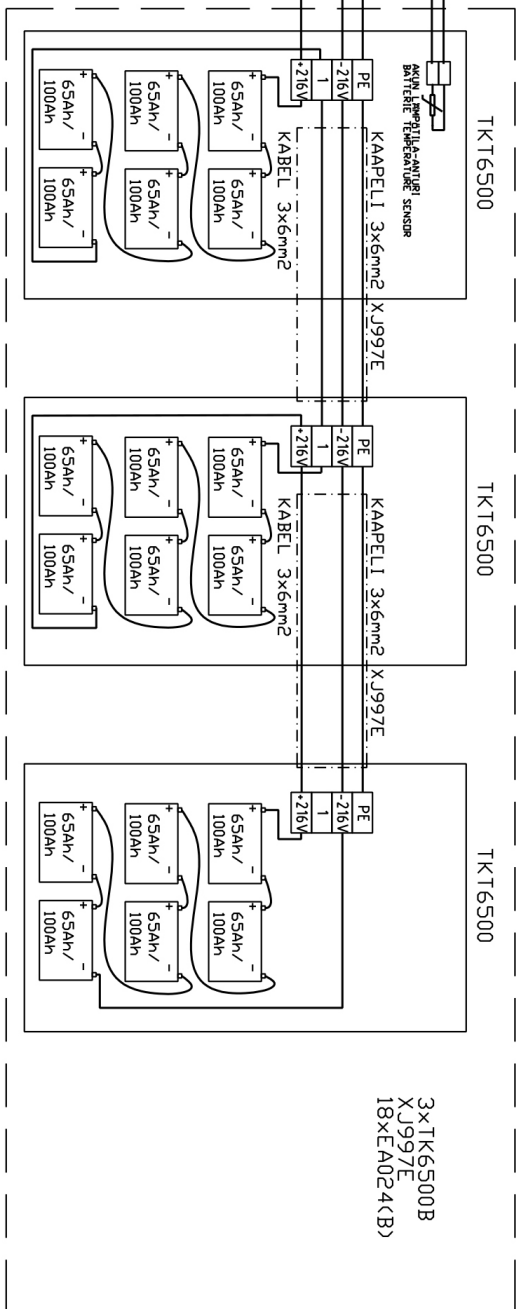
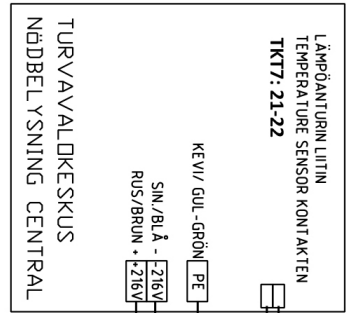

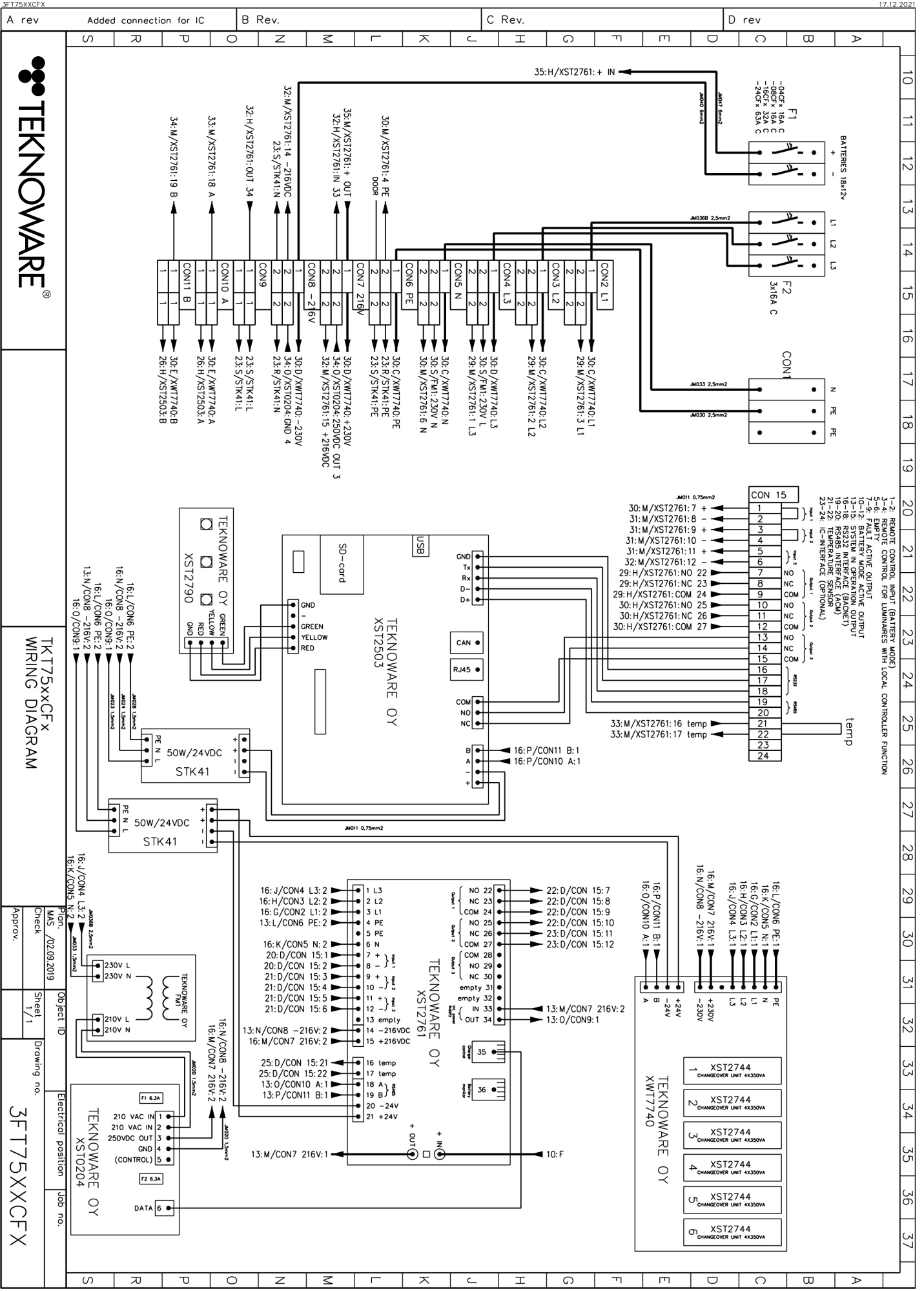

TKT75xxCFX WIRING DIAGRAM

Check	Sheet	Drawing no.	Electrical position	Job no.
Approv.	1/1	3FT75XXCFX		

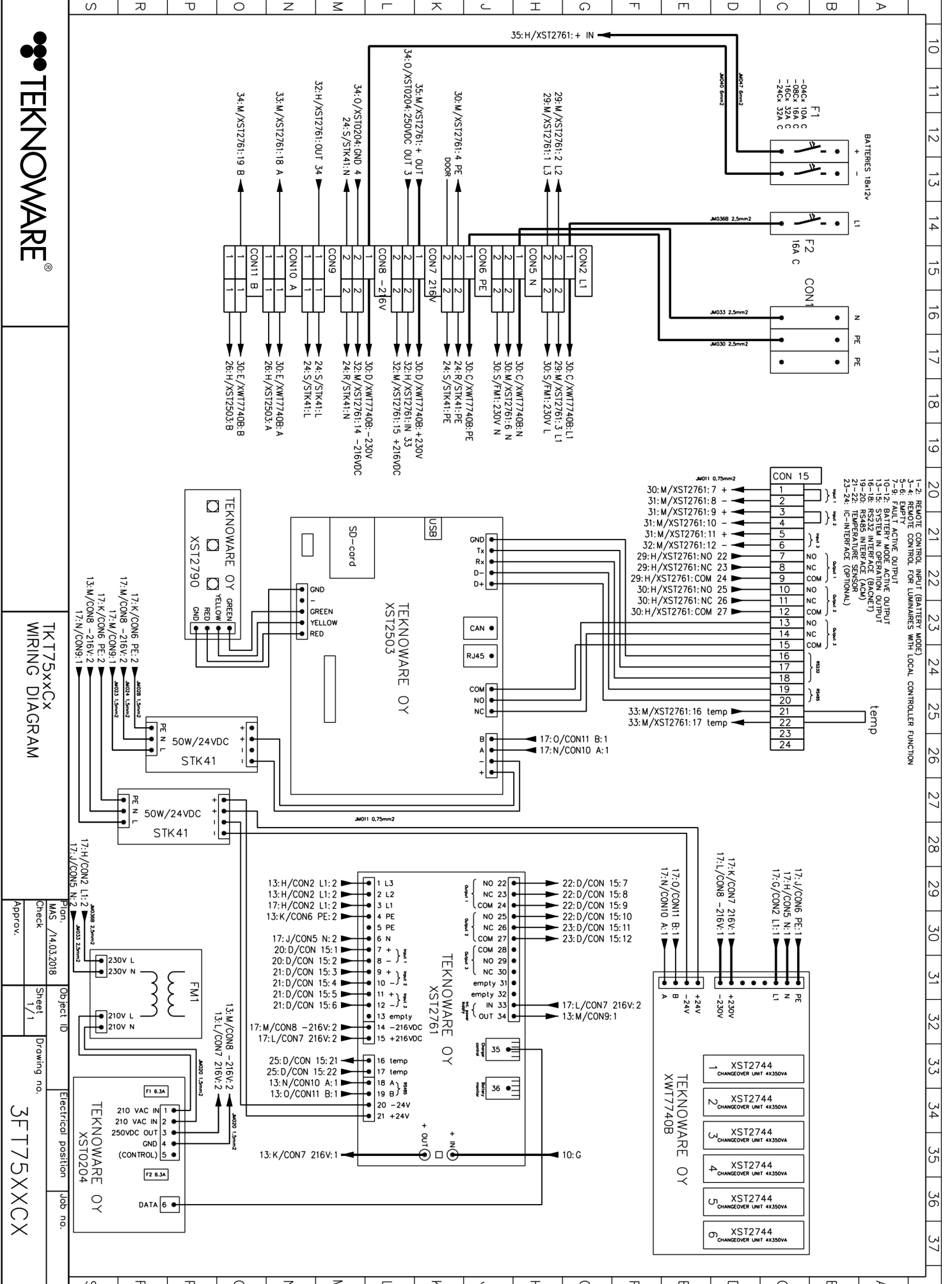

**TK175xxCx
WIRING DIAGRAM**

Pion.	MAS. /14.03.2018	Dp/fect ID	Electrical position
Check	Sheet 1/1	Drawing no.	Job no.
Approv.			

3FT75XXCX

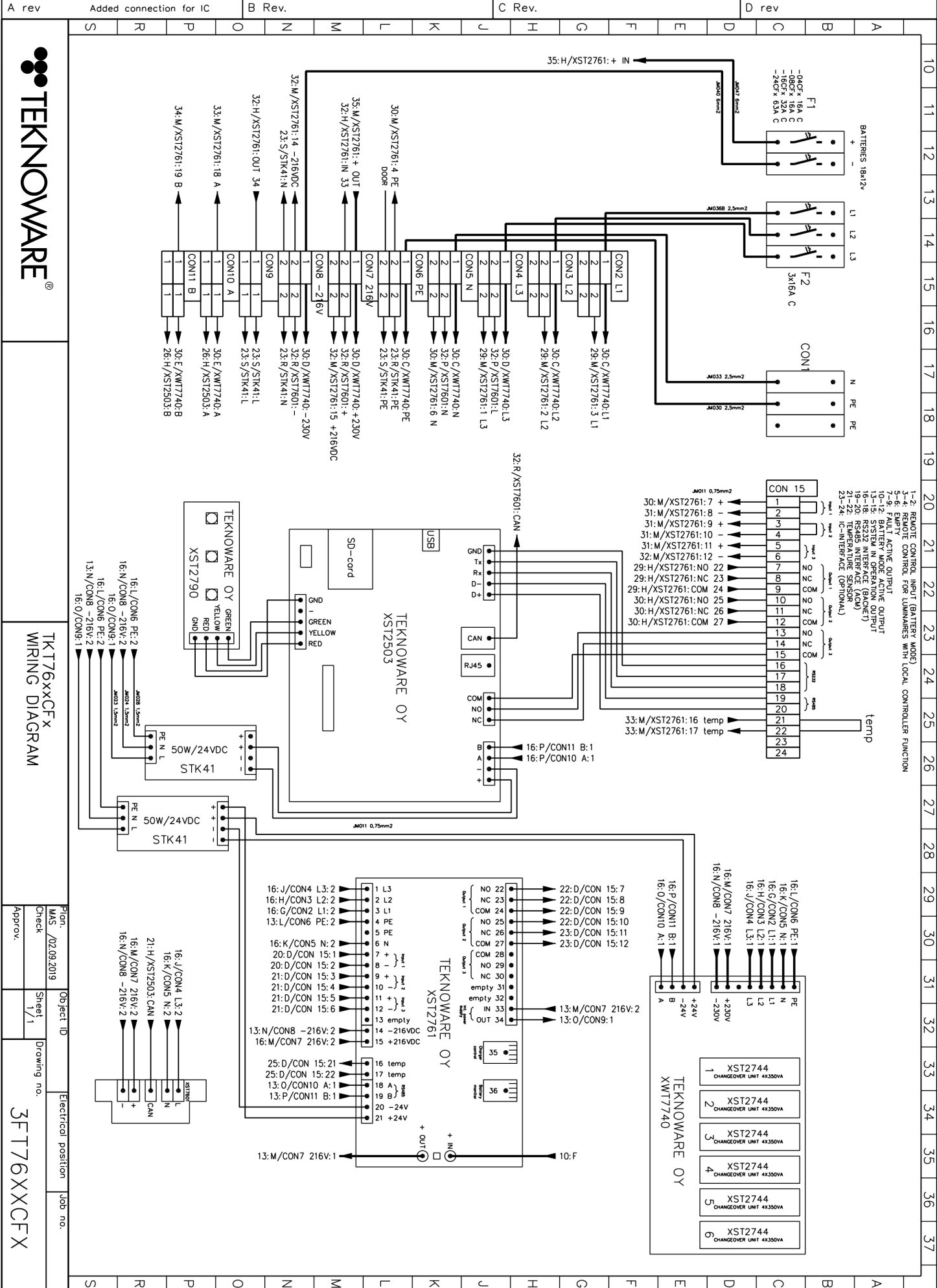

TKT76xxCFX
WIRING DIAGRAM

Plan: /02.09.2019	Object ID:	Electrical position:	Job no.:
Check	Sheet: 1/1	Drawing no.:	
Approv.:		3FT76XXCFX	

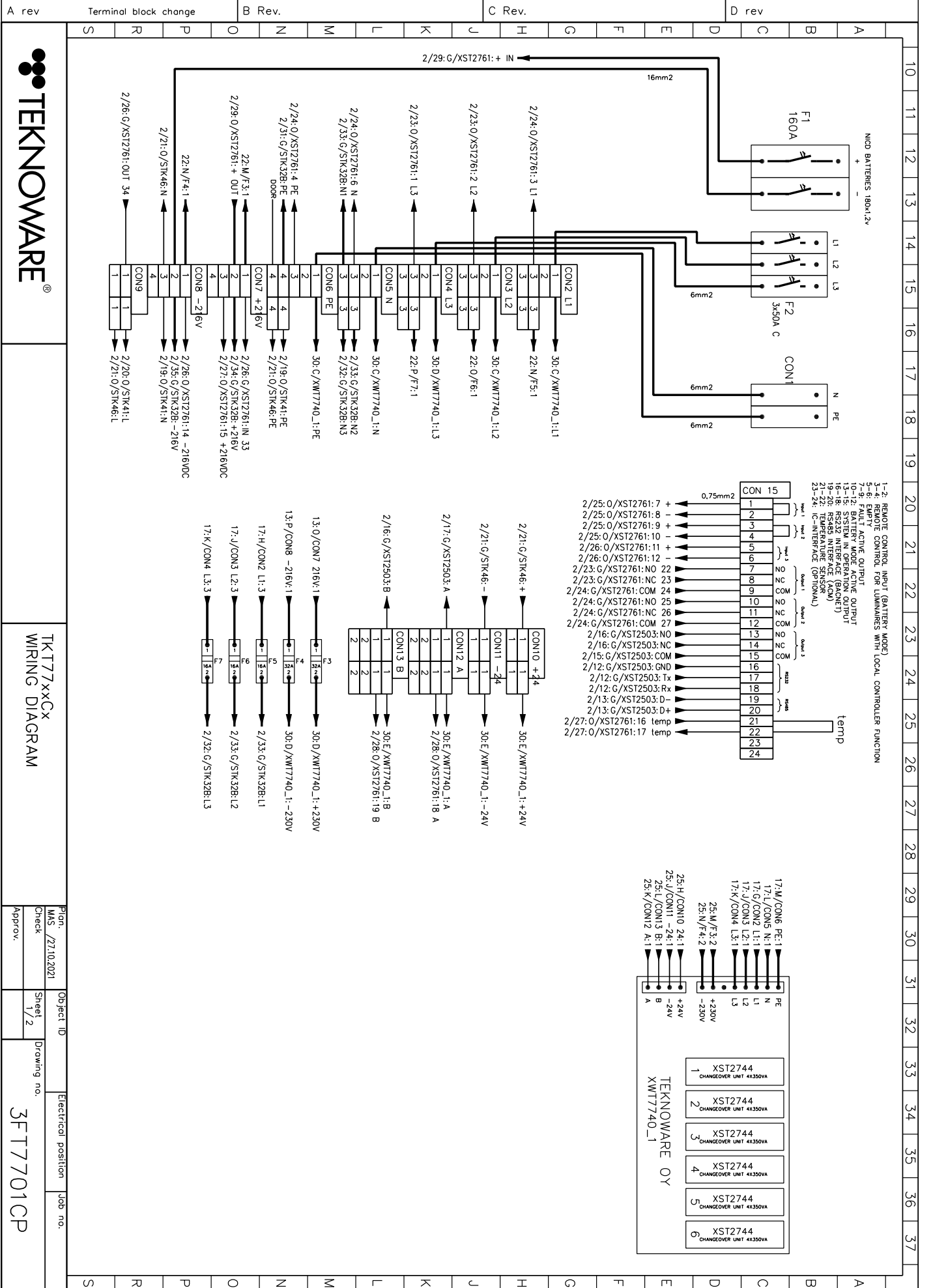

TKT77xxCx
WIRING DIAGRAM

Pon.	Objekt ID	Electrical position	Job no.
MAS / 27.10.2021			
Check	Sheet 1/2	Drawing no.	
Approv.		3FT7701CP	

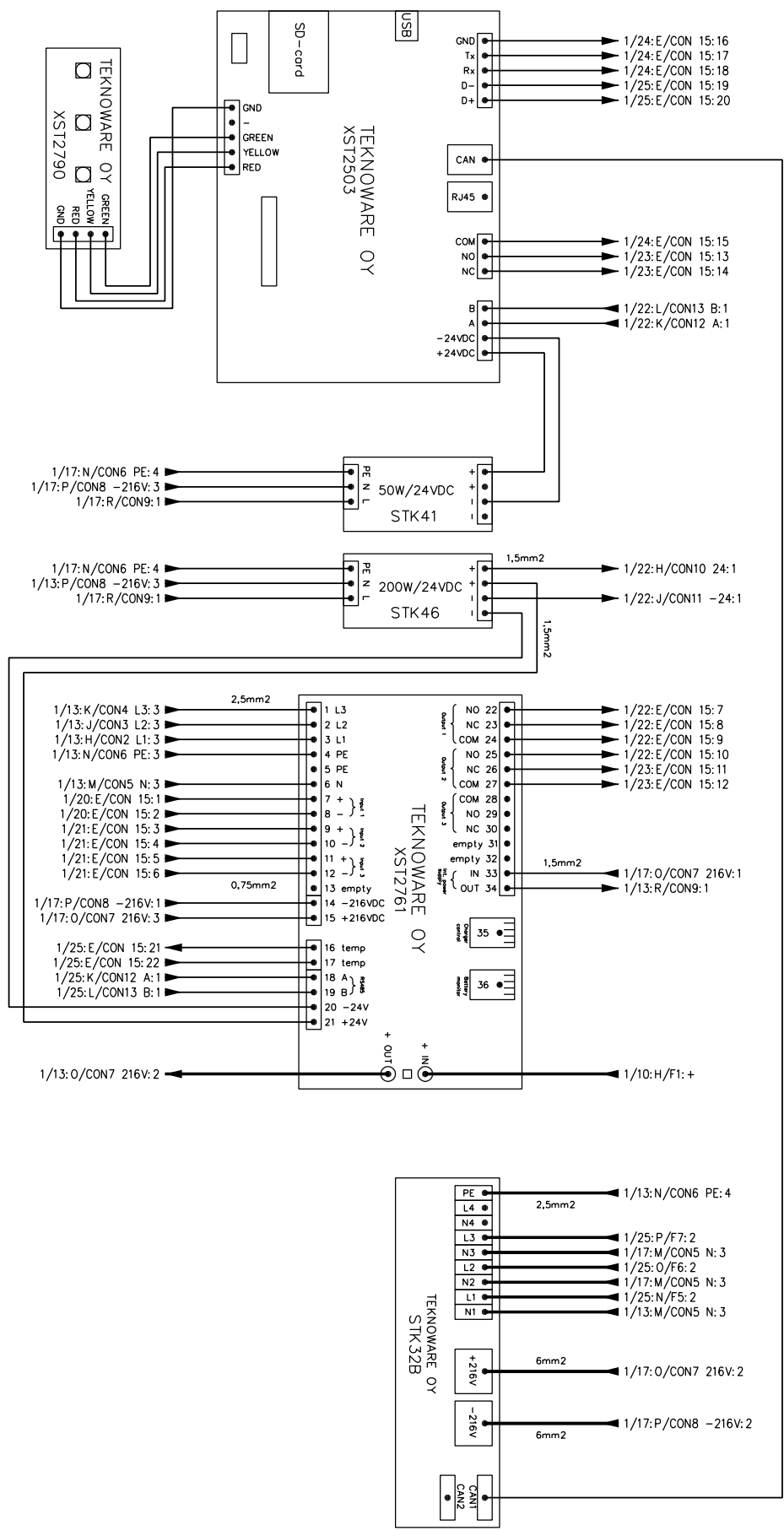

Plan	Object ID	Electrical position	Job no.
/27.10.2021			
Check	Sheet	Drawing no.	
Approv.	2/2		

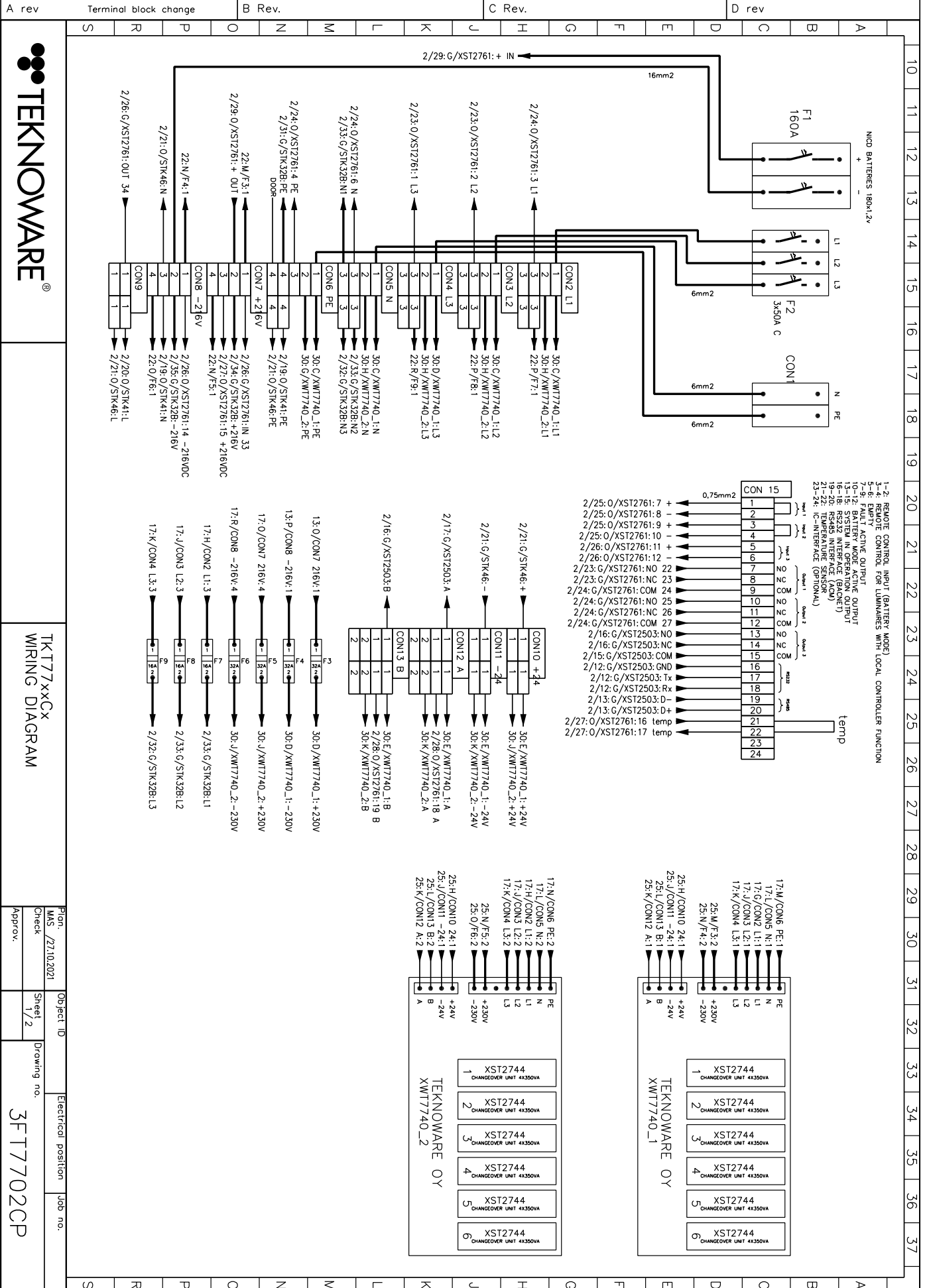

TKT77xXcX
WIRING DIAGRAM

Prom.	Object ID	Electrical position	Job no.
MMS / 27/10/2021			
Check	Sheet	Drawing no.	
	1/2	3FT7702CP	
Approv.			

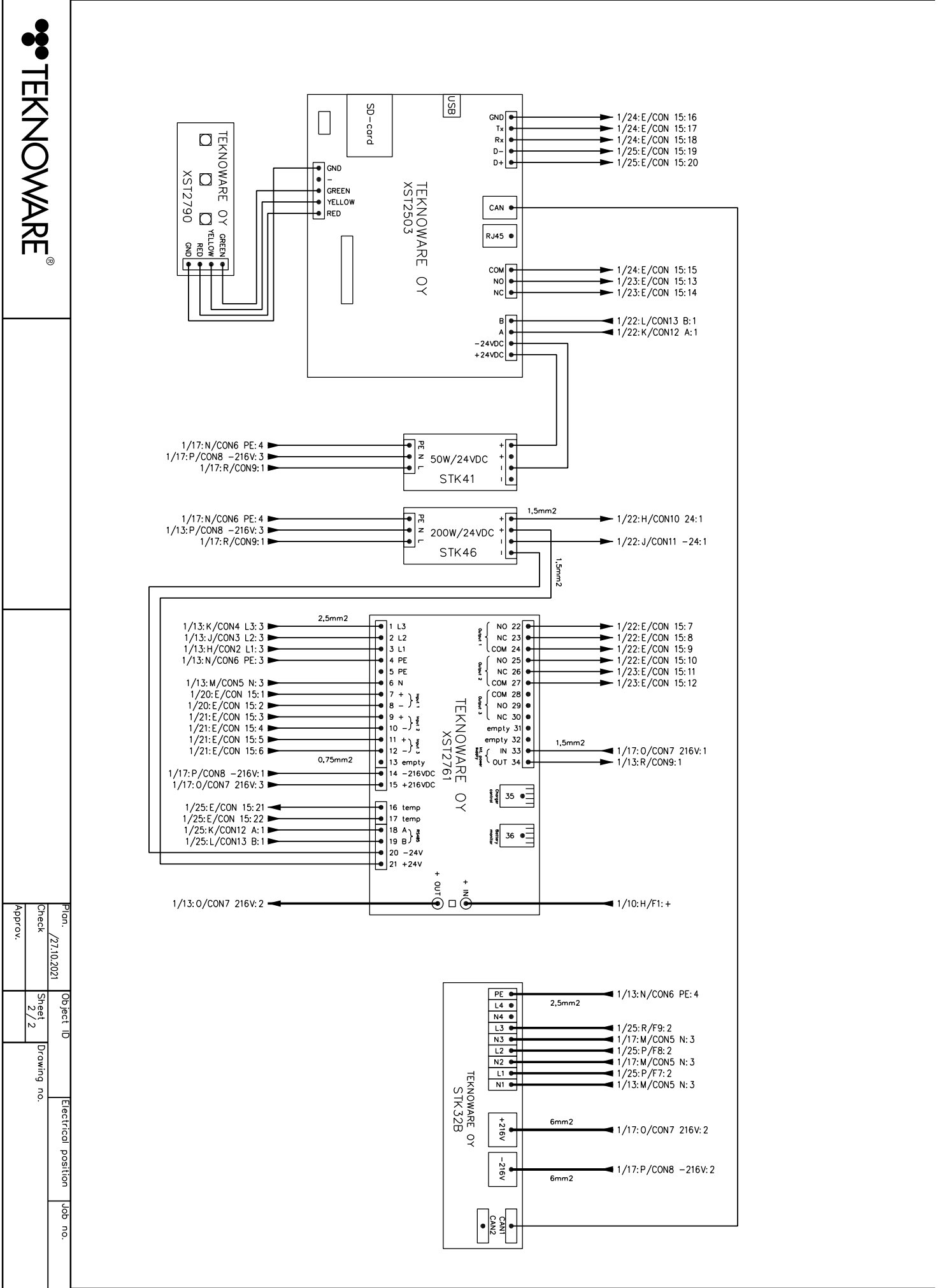

Plan.	Object ID	Electrical position	Job no.
/27.10.2021			
Check	Sheet	Drawing no.	
Approv.	2/2		

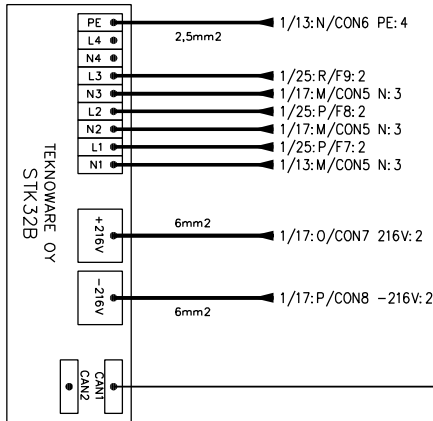

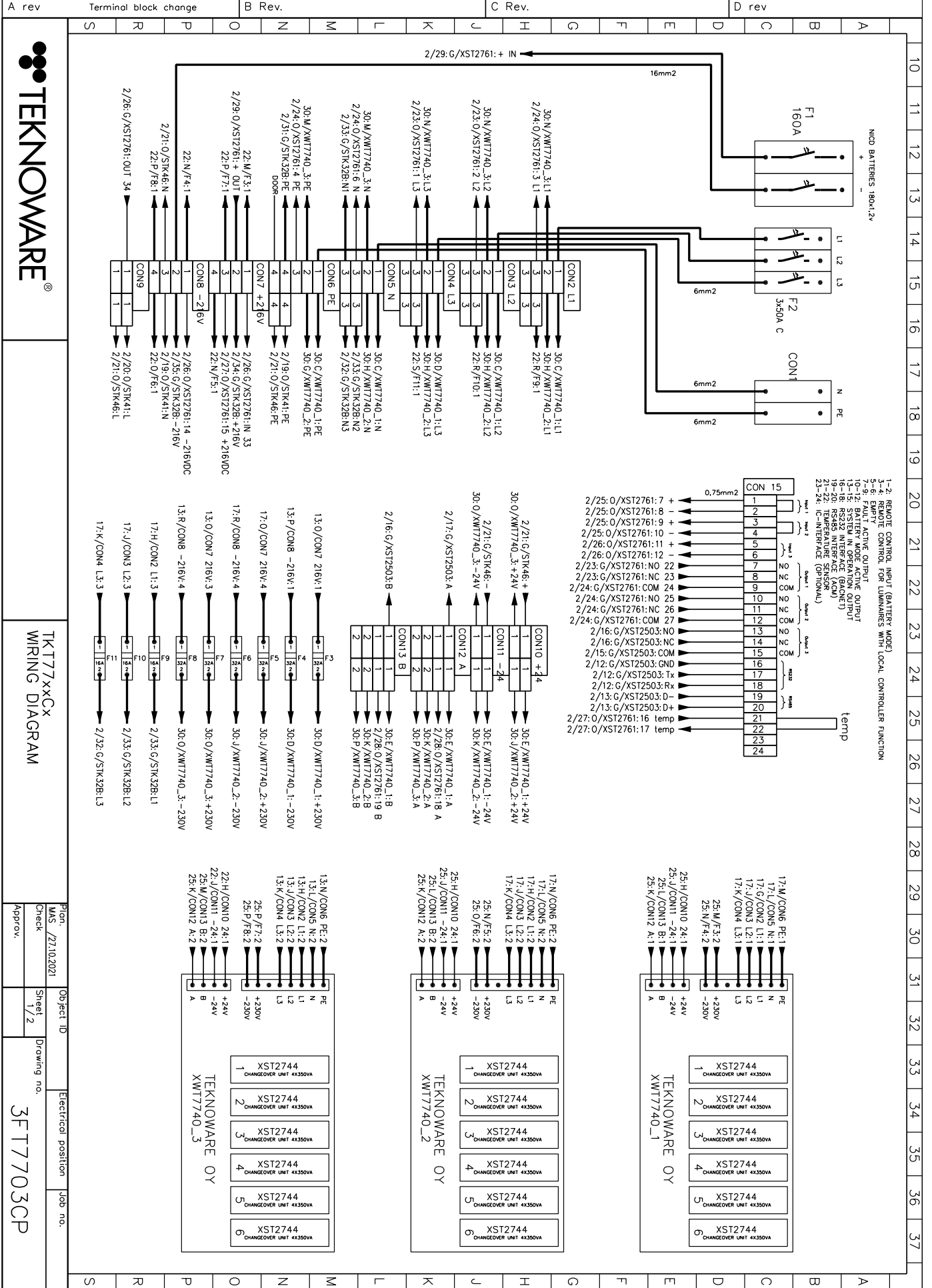

TKT77xXCX WIRING DIAGRAM

Plan. /27.10.2021	Object ID	Electrical position	job no.
Check	Sheet 1/2	Drawing no.	3FT7703CP
Approv.			

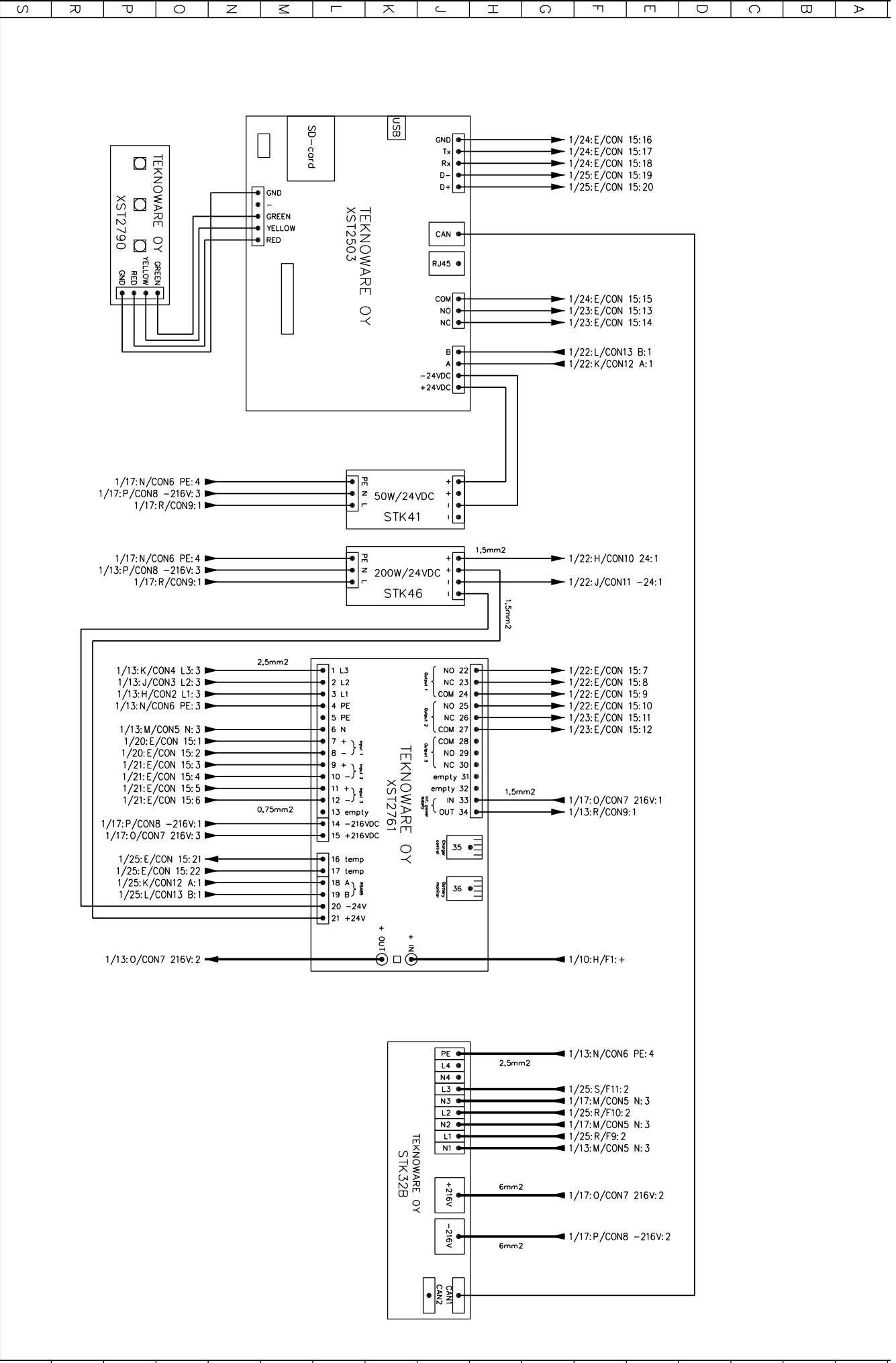

Plan	Object ID	Electrical position	Job no.
Check	Sheet	Drawing no.	
Approv.	Z/2		
/27.10.2021			

