

TEKNOWARE INTO CITY

Interior solution for buses and coaches.

Confidence is a critical function in public transportation. By combining two kinds of expertise – lighting solutions and interior structures – we aim to ease your journey towards a complete public transportation vehicle. We listen to your needs and understand what your end-users desire. We use our 50 years of experience to create a solution that ensures safety, enable comfort, provide functionality, and reflect quality. Teknoware's products are designed to last.

Our Into product family is a multifunctional bus or coach interior solution with all the features from lighting and ceiling to aircon ducting in one. These stylish ceilings are designed to withstand everything from hard shocks to heat. All materials that are in use meet the demanding requirements. Into ceilings are hardwearing but still lightweight. The colour and the finishing of the ceilings can be customized to match the interior of your bus.

When you choose us, you will get a complete interior solution from one partner to your vehicle - everything from design to manufacturing and delivery with just one agreement. When the product has the Teknoware-label on it, it guarantees that we have made it. From design to production. It is not just a label. It is a promise.

FACTS IN BRIEF

**DURABLE****COST EFFECTIVE****LIGHTWEIGHT****EASY TO INSTALL****TAILOR MADE**

Dimensions example (mm)

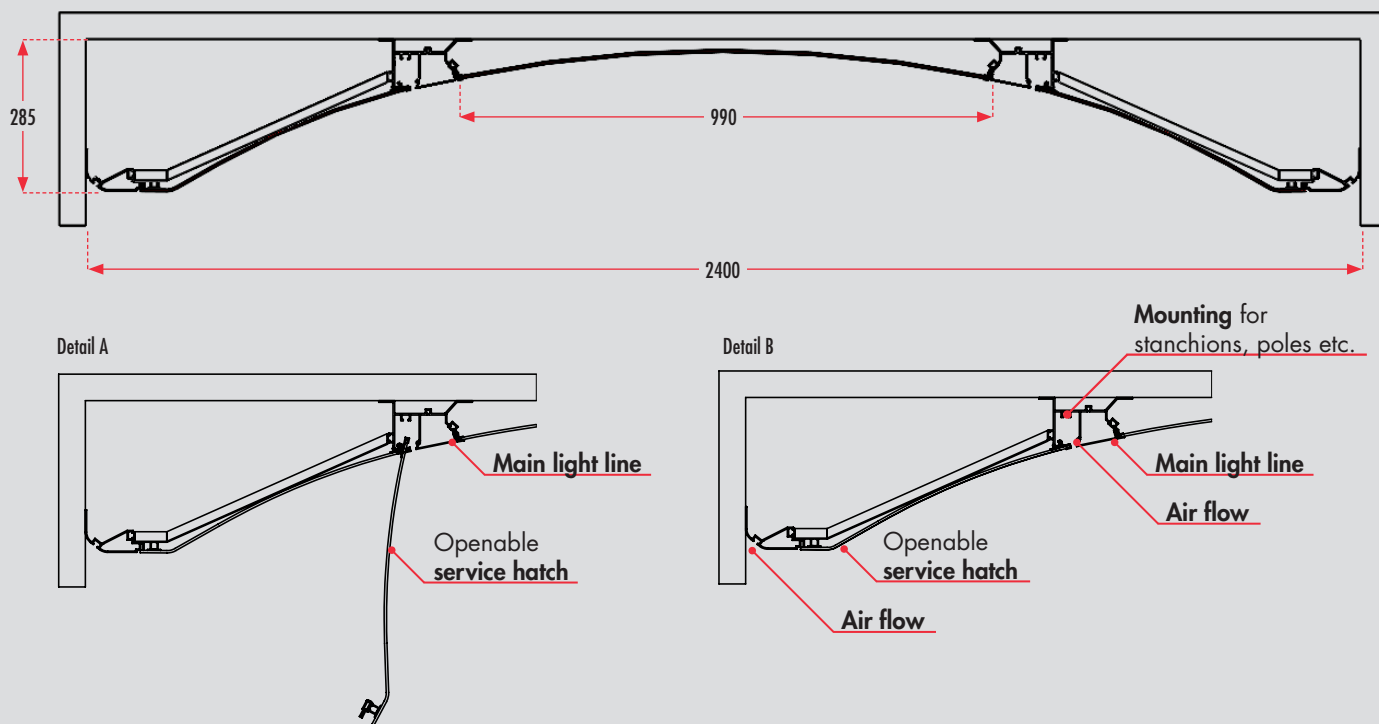

Note! The ceiling is custom made, and dimensions may vary according to your needs. In the picture above, the dimensions are just an example.

Specification

Mechanical characteristics

Product ID	1003-0929
Total estimated weight	19.4 kg / m

Ceiling

Panel characteristics

Material	High-pressure laminate with light weight foam core.
Surface finish	Matte as standard <i>More options available on request.</i>
Colour	Solid colour as standard <i>More options available on request.</i>
Weight	2.43 kg / m ²

Other characteristics

HPL properties	Tested according to EN438 and ISO 4586 for resistance to surface wear, boiling water, dry heat, impact, cracking, scratching, stains, colour change in artificial light, cigarette burns and steam.
HPL performance standards	UN ECE R118.03 BS EN 438 ISO 4586 GREENGUARD

Main lighting

Photometric features

Light output	approx. 1000 lm/m per light line
Colour temperature	3000K, 3500K, 4000K, 5000K, 5700K, 6500K

Body characteristics

Material	Aluminium
Finishing	Anodized or powder coated
Colour	Silver or customized

Diffuser characteristics

Material	Polycarbonate
Colour	Opal white

Environmental conditions

Ambient temperature range	-25°C ... +70°C
---------------------------	-----------------

Environmental characteristics

Input voltage: nominal	24 VDC
Voltage: min-max	18-32 VDC
Dimmer	PWM dimmable
LED lumen maintenance	50 000 h L70
EMC immunity	UN ECE R10
EMC emission	UN ECE R10