





# 75C

## Addressable 230 V central battery unit

<b>230V</b>	1~ N/PE 220-240 VAC 50/60 Hz	3~ N/PE 220-240 / 380-415 VAC, 50/60 Hz	<b>IP</b> <b>31</b>
<b>RAL</b> <b>9003</b>	 OTHER RAL COLOURS BY ORDER	<b>IC</b>	TapsaCtrl
<b>CE</b>	<b>EN</b> 50171	<b>EN</b> 62034	

### A smart and flexible 230 V addressable central battery unit with a touchscreen for small to medium-sized properties

The 75C central battery unit adapts to your needs flexibly, making it a long life, environmentally friendly option.

The automatic identification of addresses makes the system quick and easy to commission. The system is user-friendly, thanks to the touchscreen and the logical user interface. All tests and possible deviations in operation are stored in the internal memory, helping the maintenance of the system. The modular structure of the system allows an easy replacement of the electronics units. The 7 series is compatible with all our 230 V addressable luminaires, which makes it easy to upgrade an old central battery system. The central battery unit is easily upgraded according to the number of luminaires in the property.

Depending on the model, the 75C central battery unit has 4–24 output circuits. Max. battery capacity 65 Ah.



#### Automatic testing

The system takes care of testing automatically.

#### Self-learning system

Quick and easy commissioning. Automatic identification of addressable luminaires.

#### Simple cabling

No separate data cabling, as data is transferred via output circuit cables.

#### Several user profiles

Specification of user levels as necessary.

#### Easy to use

Touchscreen with a logical user interface as a default.

#### Capacity of output circuits can be increased

Parallel connection possible up to 1,400 W.

#### Flexible

Number of output circuits 4–24 depending on the model.

#### TapsaCtrl compatible

Compatible with all our 230 V addressable luminaires.

#### Quick backups

Backup copying of the entire system to a USB drive.

#### Easy maintenance

All tests and deviations in operation are stored in the internal memory.

#### Modular structure

Electrical modules are easy to replace thanks to the modular structure.



### HIGHLIGHTS



**AUTOMATIC  
TESTING**



**TOUCH-  
SCREEN**



**SEVERAL  
USER PROFILES**



**MODULAR**

## Technical data

Product code	Max. input power, mains supply	Number of output circuits	Max. total load, mains supply	Max. total load, battery operation 1 h	Max. total load, battery operation 3 h	Weight
<b>Nominal supply voltage 1~ N/PE 220–240 VAC, 50/60 Hz</b>						
TKT7504CP	2,515 VA	4 x 350 VA	1,400 VA	1,400 W	1,400 W	56.2 kg
TKT7508CP	3,695 VA	8 x 350 VA	2,580 VA	2,800 W	2,800 W	57 kg
TKT7516CP	3,695 VA	16 x 350 VA	2,580 VA	5,600 W	3,340 W	58.6 kg
TKT7524CP	3,695 VA	24 x 350 VA	2,580 VA	6,000 W	3,340 W	60.2 kg
<b>Nominal supply voltage 3~ N/PE 220–240 / 380–415 VAC, 50/60 Hz</b>						
TKT7508CFP	3,915 VA	8 x 350 VA	2,800 VA	2,800 W	2,800 W	57 kg
TKT7516CFP	6,715 VA	16 x 350 VA	5,600 VA	5,600 W	3,340 W	58.6 kg
TKT7524CFP	9,515 VA	24 x 350 VA	8,400 VA	6,000 W	3,340 W	60.2 kg

**System:** 230 VAC/DC | **Batteries required:** 18 x 12 V (216 V) | Short circuit current required in the circuit cable with a 2.5 A fuse and 0.4 s cut-off time: 10 A | 4 x 350 VA, 2 x 700 VA or 1 x 1,400 VA parallel connections possible | Max. circuit cable length 500 m | **Max. inrush current:** 350 W circuit (an individual circuit): 120 A/1 ms | 700 W circuit (two circuits in parallel): 250 A/1 ms | 1,400 W circuit (four circuits in parallel): 300 A/1 ms | Up to 32 luminaires can be mounted in a circuit (in the EU, regulated to 20 luminaires/circuit).

## Dimensions [mm]

### 75C central battery unit

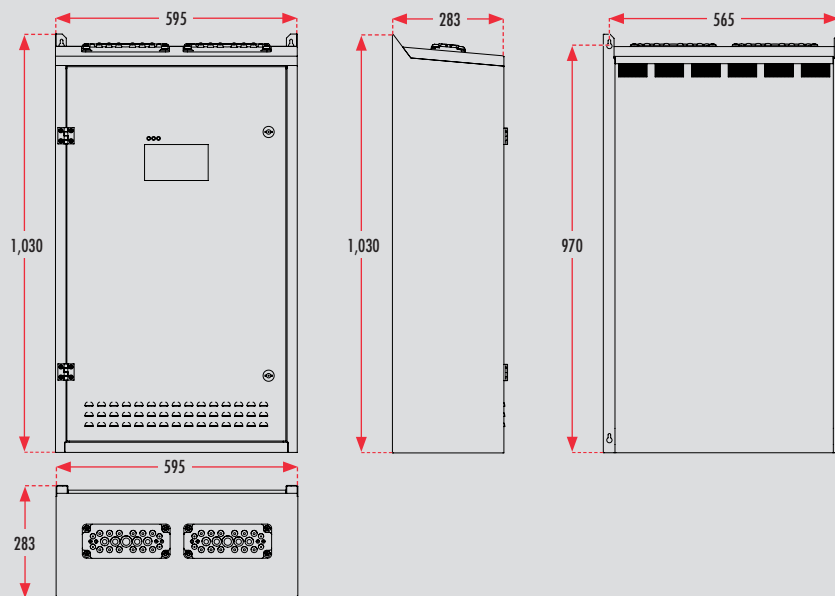

Further information on additional accessories, p. 14 onwards

## Batteries (18 needed)

Product code	Battery size	Max. total load, operation 1 h	Max. total load, operation 3 h	Suitable battery cabinet	Suitable battery cables	Dimensions	Weight
TEA020	6.5 Ah	680 W	280 W	TK6500B(P)	XJ997B	151 x 65 x 102 mm	2.5 kg
TEA021	15 Ah	1,920 W	790 W	TK6500B(P)	XJ997	183 x 79 x 169 mm	5.7 kg
TEA022	24 Ah	2,700 W	1,120 W	TK6500B x 2 TK6500BP x 3	XJ997C XJ997E	167 x 177 x 126 mm	7.9 kg
TEA023	38 Ah	3,770 W	1,730 W	TK6500B x 2 TK6500BP x 3	XJ997C XJ997E	199 x 167 x 172 mm	12.2 kg
TEA024	65 Ah	6,600 W	3,030 W	TKT6600P x 2 TKT6500(P) x 3	XJ997C XJ997E	350 x 169 x 180 mm	19.2 kg

A 10 % reserve is recommended for the loads mentioned in the table (W)

## Optional accessories

Product code	Product description	Operation
TST7750	IC interface	7 series
TST7504, TST7508, TST7516, TST7524	Terminal blocks *	75C, 76C and 78C central battery units



\* Separate DIN rail output connectors. By default, the output circuits are connected directly to the changeover modules.

## Optional remote monitoring systems

Product code	Product description	Operation
TWC1000	MyTeknoware licence	7 series
TST7561	WebACM software	7 series
TST7531	ACM software	7 series

# 76C

## Addressable 230 V central battery unit

<b>230V</b>	3~ N/PE 220-240 / 380-415 VAC, 50/60 Hz	<b>IP</b> <b>31</b>	
<b>RAL</b> <b>9003</b>	 OTHER RAL COLOURS BY ORDER	<b>IC</b>	TapsaCtrl
<b>CE</b>	<b>EN</b> 50171	<b>EN</b> 62034	

### A smart and flexible 230 V addressable central battery unit with a touchscreen for small to medium-sized and large properties

The 76C central battery unit adapts to your needs flexibly, making a 7 series system a long life, environmentally friendly option.

The automatic identification of addresses makes the system quick and easy to commission. The system is user-friendly, thanks to the touchscreen and the logical user interface. All tests and possible deviations in operation are stored in the internal memory, helping the maintenance of the system. The modular structure of the system allows an easy replacement of the electronics units. The 7 series is compatible with all our 230 V addressable luminaires, which makes it easy to upgrade an old central battery system. The central battery unit is easily upgraded according to the number of luminaires in the property.

Depending on the model, the 76C central battery unit has 4–24 output circuits. Max. battery capacity 150 Ah.



#### Automatic testing

The system takes care of testing automatically.

#### Self-learning system

Quick and easy commissioning. Automatic identification of luminaire addresses.

#### Simple cabling

No separate data cabling, as data is transferred via output circuit cables.

#### Several user profiles

Specification of user levels as necessary.

#### Easy to use

Touchscreen with a logical user interface as a default.

#### Capacity of output circuits can be increased

Parallel connection possible up to 1,400 W.

#### Flexible

Number of output circuits 4–24 depending on the model.

#### TapsaCtrl compatible

Compatible with all our 230 V addressable luminaires.

#### Quick backups

Backup copying of the entire system to a USB drive.

#### Easy maintenance

All tests and deviations in operation are stored in the internal memory.

#### Modular structure

Electrical modules are easy to replace thanks to the modular structure.



### HIGHLIGHTS



**AUTOMATIC TESTING**



**TOUCH-SCREEN**



**SEVERAL USER PROFILES**



**MODULAR**

## Technical data

Product code	Max. input power mains supply	Number of output circuits	Max. total load, mains supply	Max. total load, battery operation 1 h	Max. total load, battery operation 3 h	Weight
<b>Nominal supply voltage</b> 3~ N/PE 220–240 / 380–415 VAC, 50/60 Hz						
TKT7604CFP	4,165 VA	4 x 350 VA	1,400 VA	1,400 W	1,400 W	46 kg
TKT7608CFP	5,565 VA	8 x 350 VA	2,800 VA	2,800 W	2,800 W	46.8 kg
TKT7616CFP	8,365 VA	16 x 350 VA	5,600 VA	5,600 W	5,600 W	48.4 kg
TKT7624CFP	11,165 VA	24 x 350 VA	8,400 VA	8,400 W	7,580 W	50 kg

**System:** 230 VAC/DC | **Batteries required:** 18 x 12 V ( 216 V ) | Short circuit current required in the circuit cable with a 2.5 A fuse and 0.4 s cut-off time: 10 A | 4 x 350 VA, 2 x 700 VA or 1 x 1,400 VA parallel connections possible | Max. circuit cable length 500 m | **Max. inrush current:** 350 W circuit (an individual circuit): 120 A/1 ms | 700 W circuit (two circuits in parallel): 250 A/1 ms | 1,400 W circuit (four circuits in parallel): 300 A/1 ms | Up to 32 luminaires can be mounted in a circuit (in the EU, regulated to 20 luminaires/circuit).

## Dimensions [mm]

### 76C central battery unit

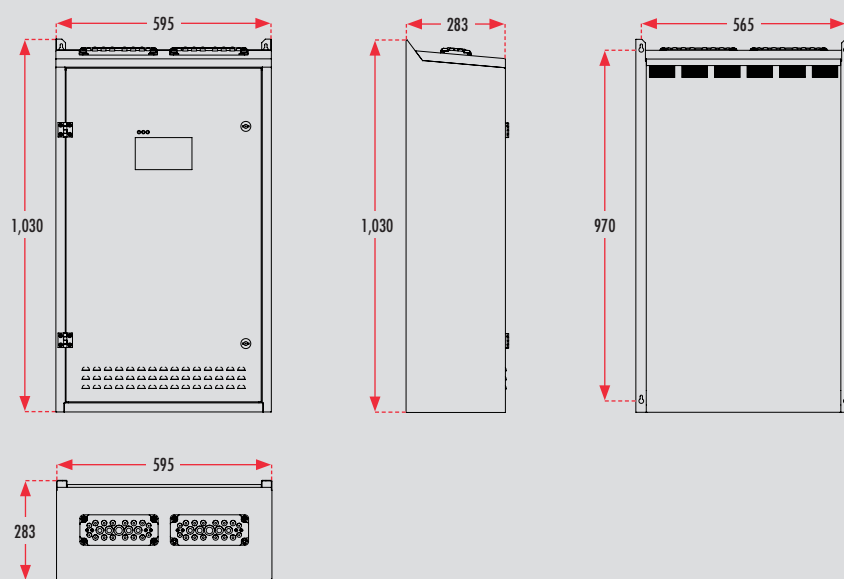

Further information on additional accessories, p. 14 onwards

## Batteries (18 needed)

Product code	Battery size	Max. total load, operation 1 h	Max. total load, operation 3 h	Suitable battery cabinet	Suitable battery cables	Dimensions	Weight
TEA024	65 Ah	6,600 W	3,030 W	TKT6600P x 2 TKT6500(P) x 3	XJ997C XJ997E	350 x 169 x 180 mm	19.2 kg
TEA024B	100 Ah	10,140 W	4,660 W	TKT6600P x 2 TKT6500(P) x 3	XJ997C XJ997E	305 x 168 x 228 mm	30.8 kg
TEA024D	150 Ah	15,230 W	7,250 W	TKT6600P x 2	XJ997H	485 x 172 x 240 mm	47 kg

A 10% reserve is recommended for the loads mentioned in the table (W)

## Optional accessories

Product code	Product description	Operation
TST7750	IC interface	7 series
TST7504, TST7508, TST7516, TST7524	Terminal blocks *	75C, 76C and 78C central battery units



\* Separate DIN rail output connectors. By default, the output circuits are connected directly to the changeover modules.

## Optional remote monitoring systems

Product code	Product description	Operation
TWC1000	MyTeknoware licence	7 series
TST7561	WebACM software	7 series
TST7531	ACM software	7 series

# 77C

## Addressable 230 V central battery unit

<b>230V</b>	3~ N/PE 220-240 / 380-415 VAC, 50/60 Hz	<b>IP</b> <b>31</b>	
<b>RAL</b> <b>9003</b>	 OTHER RAL COLOURS BY ORDER	<b>IC</b>	TapsaCtrl
<b>CE</b>	<b>EN</b> 50171	<b>EN</b> 62034	

### An efficient and flexible 230 V addressable central battery unit with a touchscreen for large properties

The 77C central battery unit is a smart solution providing a high quality of emergency lighting for large properties in particular. The system adapts to your needs flexibly, making a 7 series system a long life, environmentally friendly option.

The automatic identification of addresses makes the system quick and easy to commission. The system is easy to use, thanks to the touchscreen and the logical user interface. All tests and possible deviations in operation are stored in the internal memory, helping the maintenance of the system. The modular structure of the system allows an easy replacement of the electronics units. The 7 series is compatible with all our 230 V addressable luminaires, which makes it easy to upgrade an old central battery system. The central battery unit is easily upgraded according to the number of luminaires in the property.

Depending on the model, the 77C central battery unit has 24–72 output circuits. Max. battery capacity 450 Ah (with additional chargers, see p. 23 for more information).



#### Automatic testing

The system takes care of testing automatically.

#### Self-learning system

Quick and easy commissioning. Automatic identification of luminaire addresses.

#### Simple cabling

No separate data cabling, as data is transferred via output circuit cables.

#### Several user profiles

Specification of user levels as necessary.

#### Easy to use

Touchscreen with a logical user interface as a default.

#### Capacity of output circuits can be increased

Parallel connection possible up to 1,400 W.

#### Flexible

Number of output circuits 24–72 depending on the model.

#### TapsaCtrl compatible

Compatible with all our 230 V addressable luminaires.

#### Quick backups

Backup copying of the entire system to a USB drive.

#### Easy maintenance

All tests and deviations in operation are stored in the internal memory.

#### Modular structure

Electrical modules are easy to replace thanks to the modular structure.



### HIGHLIGHTS



**AUTOMATIC TESTING**



**TOUCH-SCREEN**



**SEVERAL USER PROFILES**



**MODULAR**



**MAX. BATTERY CAPACITY 450 AH**

## Technical data

Product code	Max. input power mains supply	Number of output circuits	Max. total load, mains supply	Max. total load, battery operation 1 h	Max. total load, battery operation 3 h	Weight
<b>Nominal supply voltage</b> 3~ N/PE 220–240 / 380–415 VAC, 50/60 Hz						
TKT7724CP	16,695 VA	24 x 350 VA	8,400 VA	8,400 W	8,400 W	102.2 kg
TKT7732CP	19,510 VA	32 x 350 VA	11,200 VA	11,200 W	11,200 W	106.5 kg
TKT7740CP	22,310 VA	40 x 350 VA	14,000 VA	14,000 W	14,000 W	108.1 kg
TKT7748CP	25,110 VA	48 x 350 VA	16,800 VA	16,800 W	16,800 W	109.7 kg
TKT7756CP	27,910 VA	56 x 350 VA	19,600 VA	19,600 W	19,600 W	114 kg
TKT7764CP	30,710 VA	64 x 350 VA	22,400 VA	22,400 W	22,400 W	115.6 kg
TKT7772CP	33,510 VA	72 x 350 VA	25,200 VA	25,200 W	22,740 W	117.2 kg

**System:** 230 VAC/DC | **Batteries required:** 18 x 12 V (216 V) | Short circuit current required in the circuit cable with a 2.5 A fuse and 0.4 s cut-off time: 10 A | 4 x 350 VA, 2 x 700 VA or 1 x 1,400 VA parallel connections possible | Max. circuit cable length 500 m | **Max. inrush current:** 350 W circuit (an individual circuit): 120 A/1 ms | 700 W circuit (two circuits in parallel): 250 A/1 ms | 1,400 W circuit (four circuits in parallel): 300 A/1 ms | Up to 32 luminaires can be mounted in a circuit (in the EU, regulated to 20 luminaires/circuit).

## Dimensions [mm]

### 77C central battery unit

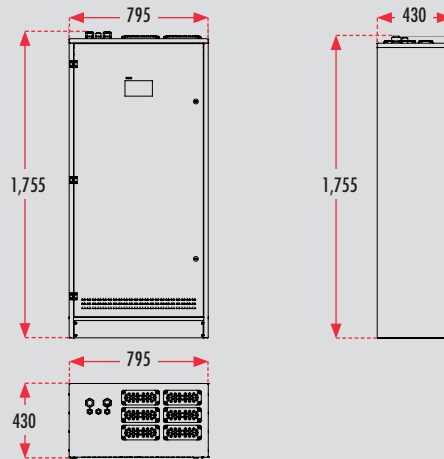

## Batteries (18 needed)

Product code	Battery size	Max. total load, operation 1 h	Max. total load, operation 3 h	Suitable battery cabinet	Suitable battery cables	Dimensions	Weight
TEA024	65 Ah	6,600 W	3,030 W	TKT6600P x 2 TKT6500(P) x 3	XJ997C XJ997E	350 x 169 x 180 mm	
TEA024B	100 Ah	10,140 W	4,660 W	TKT6500P x 2 TKT6500(P) x 3	XJ997C XJ997E	305 x 168 x 228 mm	30.8 kg
TEA024D	150 Ah	15,230 W	7,250 W	TKT6600P x 2	XJ997H	485 x 172 x 240 mm	47 kg
TEA024C	200 Ah	20,280 W	9,330 W	–	–	522 x 238 x 240 mm	65 kg
2 x TEA024D	300 (2 x 150) Ah	25,500 W	14,500 W	–	–		
2 x TEA024C	400 (2 x 200) Ah	–	18,660 W	–	–		
3 x TEA024D	450 (3 x 150) Ah	–	21,750 W	–	–		

| A 10% reserve is recommended for the loads mentioned in the table (W)

Further information on additional accessories, p. 14 onwards

## Optional accessories

Product code	Product description	Operation
TST7750	IC interface	7 series
TST7724, TST7732, TST7740, TST7748, TST7756, TST7764, TST7772	Terminal blocks *	77C central battery unit
TST7741	150 Ah auxiliary charger	77C central battery unit

| Note that one charger can charge a max. 150 Ah batteries  
| \* Separate DIN rail output connectors. By default, the output circuits are connected directly to the changeover modules.

## Optional remote monitoring systems

Product code	Product description	Operation
TWC1000	MyTeknoware licence	7 series
TST7561	WebACM software	7 series
TST7531	ACM software	7 series

# 78C

## Addressable 230 V central battery unit

<b>230V</b>	1~ N/PE 220-240 VAC 50/60 Hz	3~ N/PE 220-240 / 380-415 VAC, 50/60 Hz	<b>IP</b> <b>31</b>
<b>RAL</b> <b>9003</b>	 OTHER RAL COLOURS BY ORDER	<b>IC</b>	TapsaCtrl
<b>CE</b>	<b>EN</b> 50171	<b>EN</b> 62034	

A smart and flexible 230 V addressable central battery unit with a touchscreen and an integrated battery cabinet for small to medium-sized properties.

The 78C central battery unit is a smart solution providing a high quality of emergency lighting for small to medium-sized properties in particular. The system adapts to your needs flexibly, making a 7 series system a long life, environmentally friendly option.

The automatic identification of addresses makes the system quick and easy to commission. The system is easy to use, thanks to the touchscreen and the logical user interface. All tests and possible deviations in operation are stored in the internal memory, helping the maintenance of the system. The modular structure of the system allows an easy replacement of the electronics units. The 7 series is compatible with all our 230 V addressable luminaires, which makes it easy to upgrade an old central battery system. The central battery unit is easily upgraded according to the number of luminaires in the property.

Depending on the model, the 78C central battery unit has 4–24 output circuits. Max. battery capacity 65 Ah. The unit includes an integrated battery space.

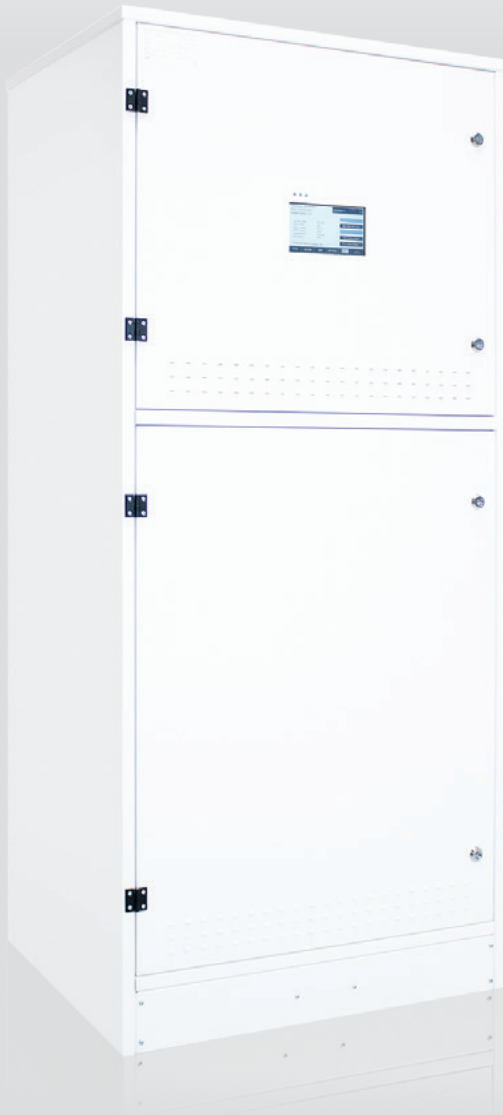

### Automatic testing

The system takes care of testing automatically.

### Self-learning system

Quick and easy commissioning.  
Automatic identification of luminaire addresses.

### Simple cabling

No separate data cabling, as data is transferred via output circuit cables.

### Integrated battery space

The unit includes an integrated battery space.

### Several user profiles

Specification of user levels as necessary.

### Easy to use

Touchscreen with a logical user interface as a default.

### Capacity of output circuits can be increased

Parallel connection possible up to 1,400 W.

### Flexible

Number of output circuits 4–24 depending on the model.

### TapsaCtrl compatible

Compatible with all our 230 V addressable luminaires.

### Quick backups

Backup copying of the entire system to a USB drive.

### Easy maintenance

All tests and deviations in operation are stored in the internal memory.

### Modular structure

Electrical modules are easy to replace thanks to the modular structure.



### HIGHLIGHTS



**AUTOMATIC TESTING**



**TOUCH-SCREEN**



**SEVERAL USER PROFILES**



**MODULAR**



**INTEGRATED BATTERY SPACE**



## Technical data

Product code	Max. input power mains supply	Number of output circuits	Max. total load, mains supply	Max. total load, battery operation 1 h	Max. total load, battery operation 3 h	Weight
<b>Nominal supply voltage 1~ N/PE 220–240 VAC, 50/60 Hz</b>						
TKT7804CP	2,515 VA	4 x 350 VA	1,400 VA	1,400 W	1,400 W	141 kg
TKT7808CP	3,695 VA	8 x 350 VA	2,580 VA	2,800 W	2,800 W	141.8 kg
TKT7816CP	3,695 VA	16 x 350 VA	2,580 VA	5,600 W	3,340 W	143.4 kg
TKT7824CP	3,695 VA	24 x 350 VA	2,580 VA	6,000 W	3,340 W	145 kg
<b>Nominal supply voltage 3~ N/PE 220–240 / 380–415 VAC, 50/60 Hz</b>						
TKT7804CFP	2,515 VA	4 x 350 VA	1,400 VA	1,400 W	1,400 W	141 kg
TKT7808CFP	3,915 VA	8 x 350 VA	2,800 VA	2,800 W	2,800 W	141.8 kg
TKT7816CFP	6,715 VA	16 x 350 W	5,600 VA	5,600 W	3,340 W	143.4 kg
TKT7824CFP	9,515 VA	24 x 350 W	8,400 VA	6,000 W	3,340 W	145 kg

**System:** 230 VAC/DC | **Batteries required:** 18 x 12 V (216 V) | Short circuit current required in the circuit cable with a 2.5 A fuse and 0.4 s cut-off time: 10 A | 4 x 350 VA, 2 x 700 VA or 1 x 1,400 VA parallel connections possible | Max. circuit cable length 500 m | **Max. inrush current:** 350 W circuit (an individual circuit): 120 A/1 ms | 700 W circuit (two circuits in parallel): 250 A/1 ms | 1,400 W circuit (four circuits in parallel): 300 A/1 ms | Up to 32 luminaires can be mounted in a circuit (in the EU, regulated to 20 luminaires/circuit).

## Dimensions [mm]

78C central battery unit

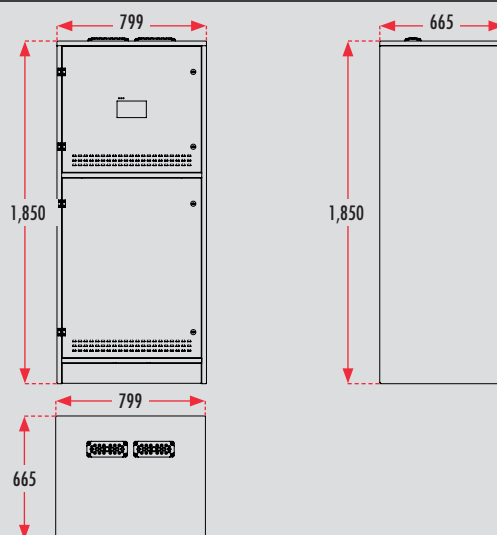

Further information on additional accessories, p. 14 onwards

## Batteries (18 needed)

Product code	Battery size	Max. total load, operation 1 h	Max. total load, operation 3 h	Suitable battery cables	Dimensions	Weight
TEA020	6.5 Ah	680 W	280 W	XJ997B	151 x 65 x 102 mm	2.5 kg
TEA021	15 Ah	1,920 W	790 W	Required battery cables are included in the delivery	183 x 79 x 169 mm	5.7 kg
TEA022	24 Ah	2,700 W	1,120 W	Required battery cables are included in the delivery	167 x 177 x 126 mm	7.9 kg
TEA023	38 Ah	3,770 W	1,730 W	Required battery cables are included in the delivery	199 x 167 x 172 mm	12.2 kg
TEA024	65 Ah	6,600 W	3,030 W	Required battery cables are included in the delivery	350 x 169 x 180 mm	19.2 kg

| A 10% reserve is recommended for the loads mentioned in the table (W)

## Optional accessories

Product code	Product description	Operation
TST7750	IC interface	7 series
TST7504, TST7508, TST7516, TST7524	Terminal blocks *	75C, 76C and 78C central battery units

| \* Separate DIN rail output connectors. By default, the output circuits are connected directly to the changeover modules.

## Optional remote monitoring systems

Product code	Product description	Operation
TWC1000	MyTeknoware licence	7 series
TST7561	WebACM software	7 series
TST7531	ACM software	7 series



# Functionality

In a normal situation, the central battery unit operates using a 230 V AC mains voltage, maintaining the battery charge level and supplying a voltage of 230 VAC to the output circuits. If the mains voltage is interrupted, the central battery unit switches to battery use. This connects a voltage of 216 VDC to the output circuits. The battery supply will be used as long as the mains voltage remains unavailable or until the battery voltage has dropped to the deep discharge limit.

## Main View

In addition to the standard functions mentioned above, the 7 series also includes monitoring, testing and reporting functions. You can access all features using the touch screen user interface.

You can see the system status at a glance without signing in. You can access other functions, according to your user level, after you have signed in.

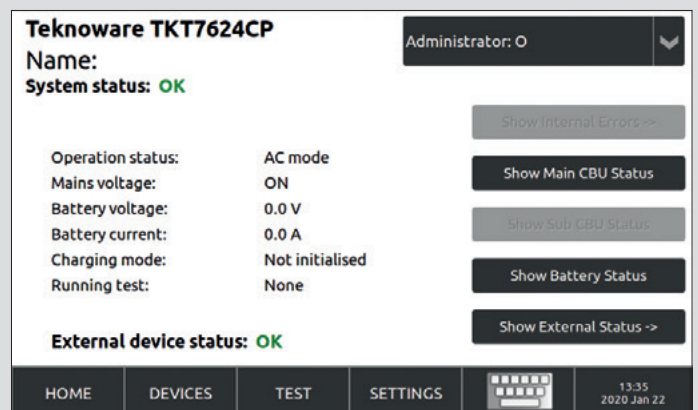

# Luminaires Overview

You can see at a glance how the luminaires are functioning: Green indicates that everything is functioning correctly; Red indicates luminaires that have reported an error. To see further information about an error, simply tap a luminaire that is marked red.

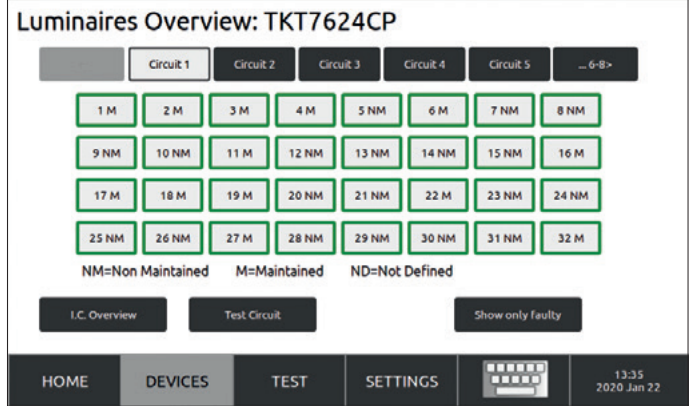
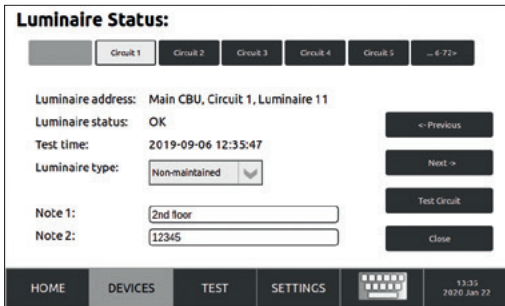

## Automatic tests

The 7 series takes care of testing luminaires automatically, as well as monitoring their operation and indicating the addresses of faulty luminaires. Battery testing is also automated.

You can define when the automatic tests are carried out. You can set the time intervals between duration tests and between luminaire tests, as well as setting the time of day the tests are carried out.

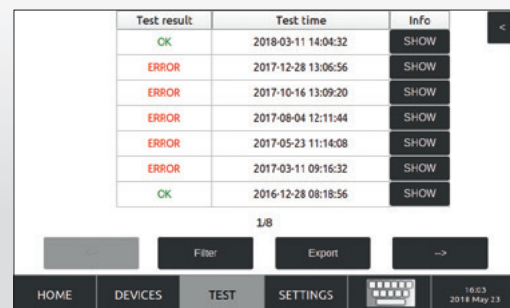
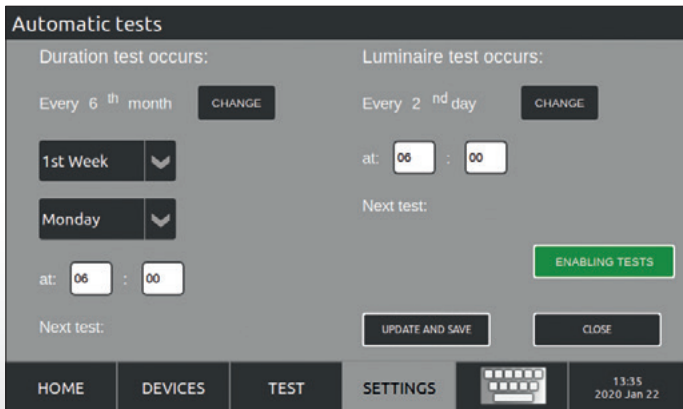

You can check the log of previous luminaire tests. This includes a list of errors and further details about each test.

## Settings

The 7 series allows you to define your settings according to your needs. You can, for example, define different user levels according to usage.

Commissioning the central battery system is easy because it automatically detects and adds luminaires to the system. You can also create a backup of the CBU database on a USB drive. The database contains all settings, including user-profiles and circuit and luminaire data. If needed, you can load a previously saved CBU backup database from a USB drive.

The 7 series also contains the network settings used for direct connection, WebACM and ACM connections, and MyTeknoware connections.

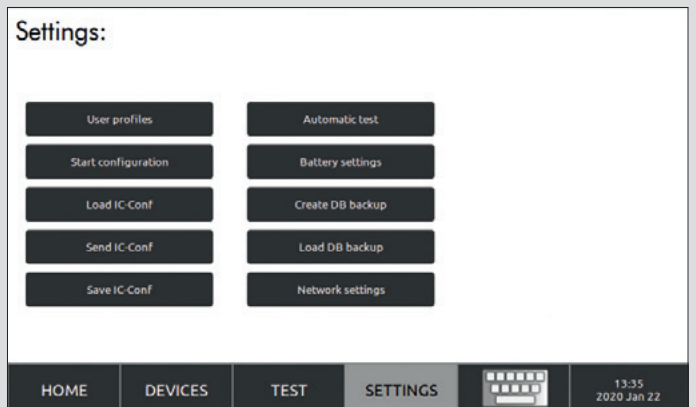

# TapsaCtrl – an addressable central battery system

## TapsaCtrl

In terms of lifecycle costs, the addressable central battery unit is the most economical option for a centrally supplied emergency lighting solution. An addressable central battery unit has the benefit that in addition to the condition of the central battery unit, also the emergency and emergency exit lights connected to the system can be monitored centrally. Addressable central battery units are suitable for small solutions comprising a couple of dozen luminaires and one central battery unit, as well as for remotely managed solutions comprising thousands of luminaires. The system automatically performs the required luminaire and battery tests, which brings substantial savings in maintenance and repair, especially in large properties.

The system is easy to install since no separate data cables are needed. Information is transferred between the addressable central battery unit and the luminaires connected to it through circuit cabling. Since the system detects the connected luminaires automatically, it is also easy to commission and modify, if required.

The addressable system is compatible with our external modules and remote monitoring solutions. The external modules allow the separate control of luminaires according to the local needs, and the remote monitoring systems can be used for the centralised monitoring of several central battery units and for central data collection. Our addressable central battery units can also be connected to the building management system, making the monitoring and testing of emergency lighting a part of the property management.

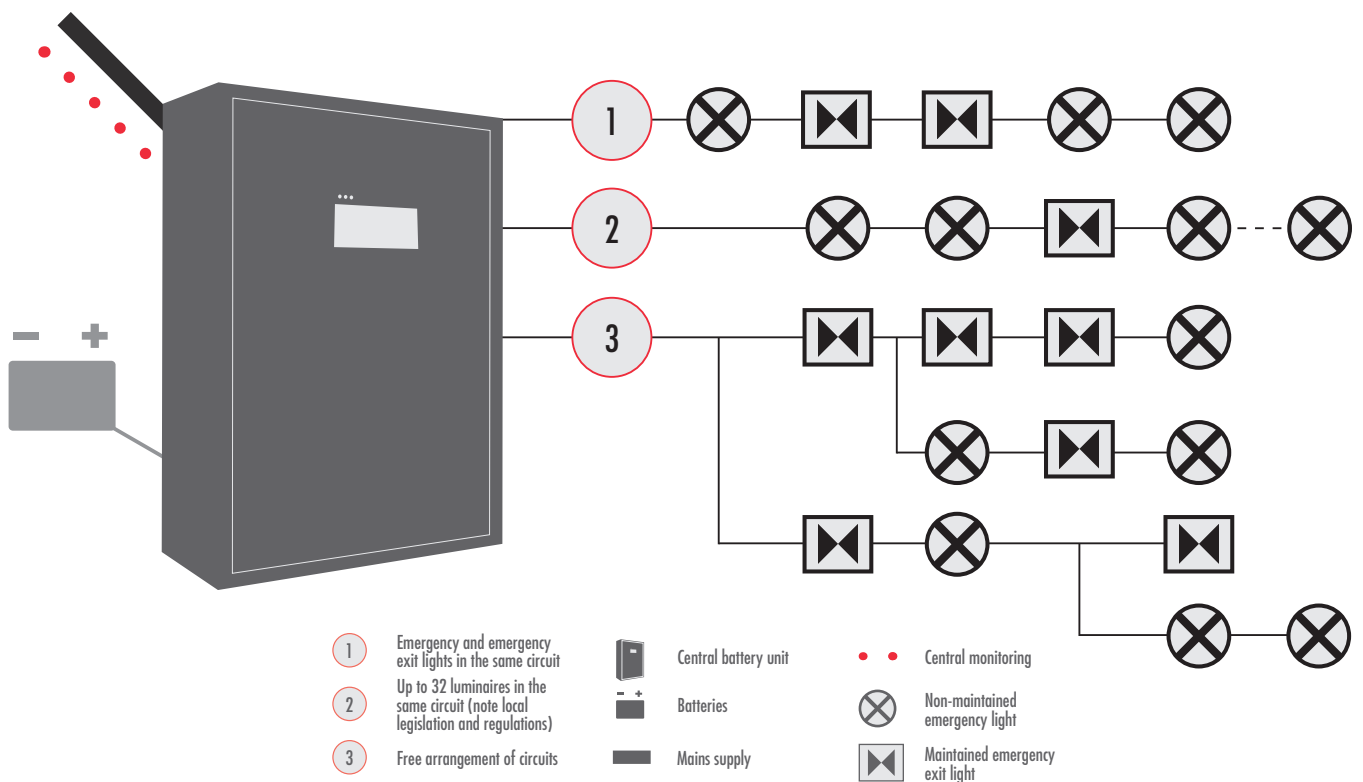

### BENEFITS

- The system is self learning, with the possibility for automatic configuration during commissioning.
- Automatic monitoring of individual luminaires and luminaire circuits, as well as battery condition.
- Automatic luminaire testing at set intervals.
- Automatic battery duration testing at set intervals.
- Several options for controlling the luminaires and for remote system monitoring.
- Up to 32 luminaires can be included in the same circuit (please note local restrictions).
- Complies with standards EN 50171 and EN 62034



## Flexibility with External Modules

With the 7 series, you can implement a fully controllable emergency lighting system throughout the whole building. You can also utilize monitoring data from various sources using our external modules.\* This enables you to adapt your emergency lighting system to various requirements.

\*The external modules **are optional**.

# Accessories

## Intelligent Controller



### For controlling non-maintained addressable emergency lights using freely chosen voltage inputs

The Intelligent Controller system (IC) enables controlling of non-maintained addressable emergency luminaires in various different situations. When the voltage in one or several distribution boards drops out, the selected emergency lights turn on with AC voltage. The emergency lights can also be used for general lighting, controlled e.g. by a switch or a motion sensor.

The IC system is compatible with our addressable 230 V central battery units and our addressable emergency luminaires. In addition to the IC Input module, an IC-interface including PC software is also required.

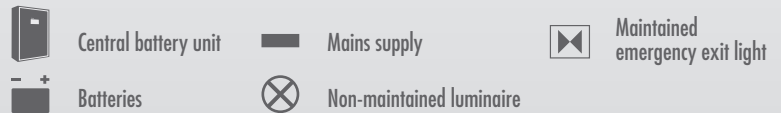
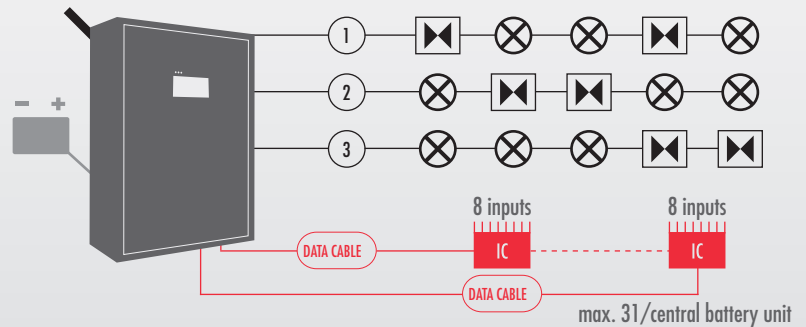

## Local Controller module



### For controlling emergency lights locally in a central battery system

The Local Controller module is used for monitoring voltage from local distribution boards and controlling the addressable emergency lights in a specific area.

Local Controller enables switching on the emergency lights in normal mode (AC), if irregularities occur in the power supply of the normal lighting. Maintained and non-maintained emergency lights can be connected to the same output circuit. Luminaires have to be of 230 V addressable type.

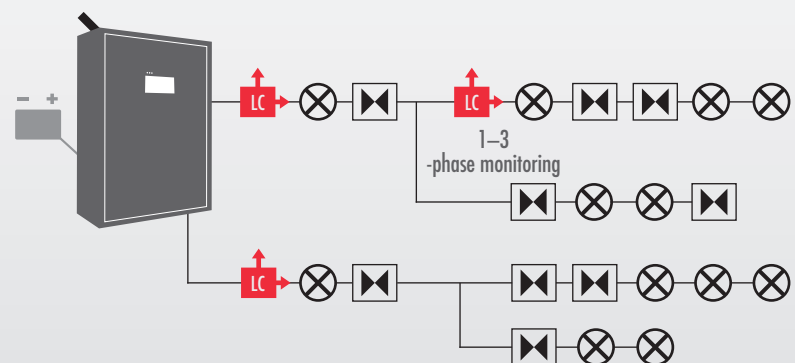

## Phase controller module



TST9601



TST9601B

### For phase monitoring of local distribution boards

The phase controller modules can be used for monitoring one to four phases in local distribution boards. The phase controller modules include two voltage free relay outputs that are activated when one or more of the circuits monitored drop out or are missing. NO or NC switching can be used for the relay outputs, and they can also be used for controlling other devices. Phase Controller can be used to switch on the addressable emergency lights, or to turn the whole system into battery mode, depending on the connection in the central battery unit.

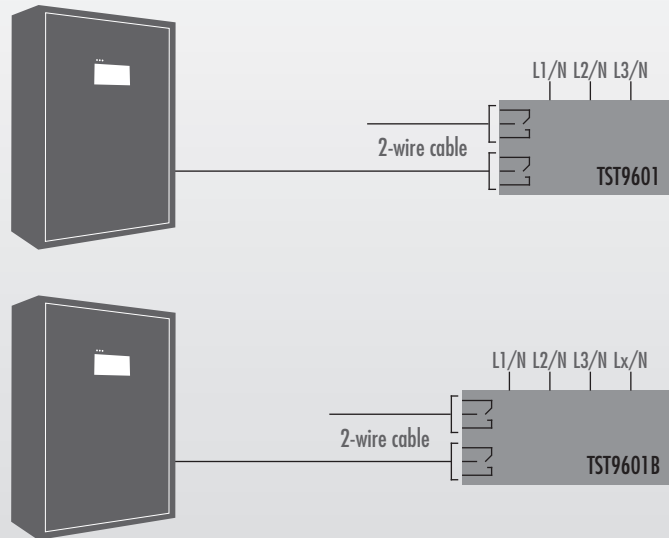

## Switch controller module



### For controlling emergency luminaires connected to the central battery unit in normal mode using a light switch

In normal mode (AC), the switch controller controls the emergency lights connected to the central battery unit with a light switch. When the central battery unit turns into emergency mode (DC), the switch controller turns on the emergency luminaires regardless of the position of the light switch.

The switch controller may also be used with the Local Controller.

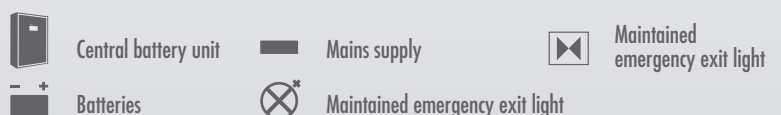
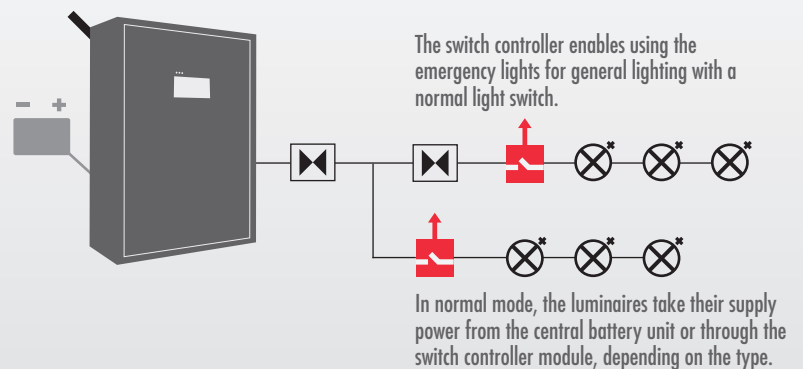

# Separate address modules for luminaires

## TS9825x and TS9826x address modules



TS98253

TS98253B

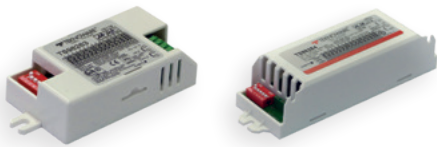

TS98263

TS98254



TS98263B

TS98255

A separate address module is needed when connecting other luminaires to addressable 230 V central battery units in addition to Teknoware luminaires. Data between the central battery unit and the luminaires equipped with address modules is transferred via circuit cabling. There's no need for separate data cabling.

The address module is connected to the circuit cable and the luminaire's connector.

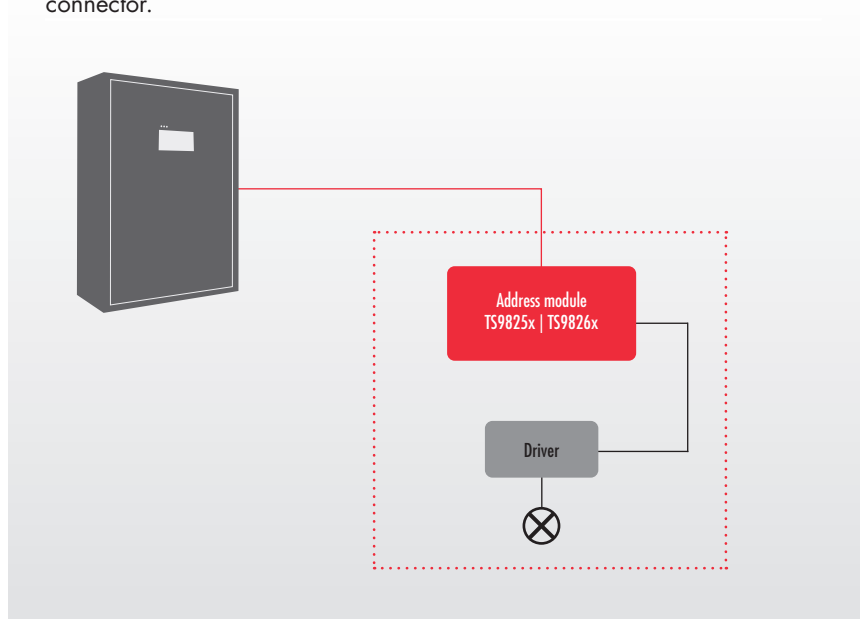

## TS98271 address module



TS98271 is a DALI compatible address module for luminaires. It simulates the operation of the DALI-master in emergency mode. TS98271 DALI address module is connected to the circuit cabling, the DALI driver and the DALI-master.

Brightness in emergency mode can be set to 10–100%.

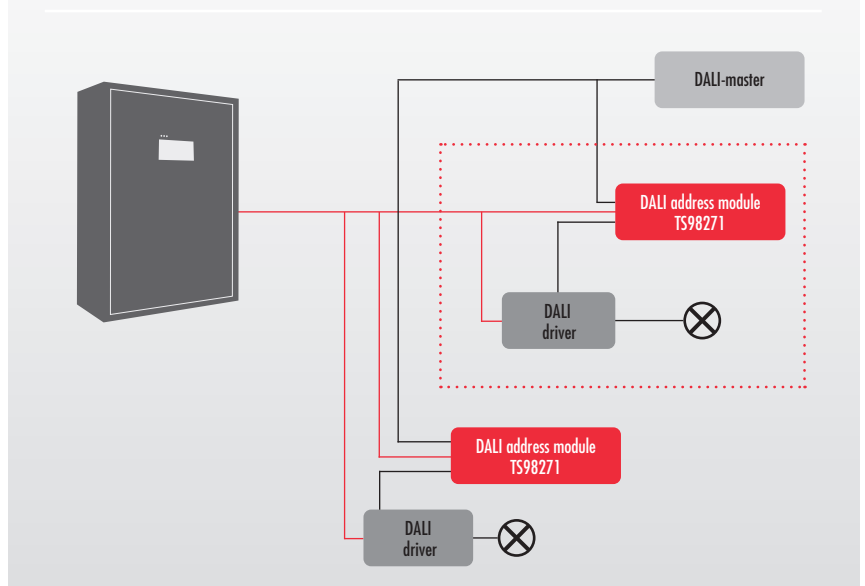



## TS98281 address module



TS98281 is an address module with switch control and phase control inputs. The principle of operation is the same as in the Local Controller module and the switch controller module. The address module is intended for one luminaire and one phase input.

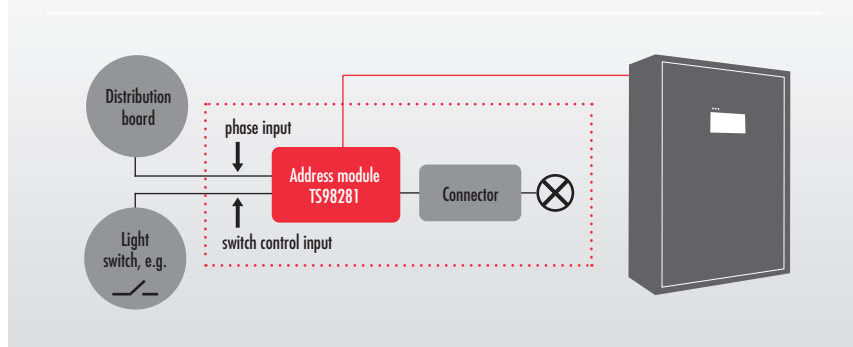

Product code	Standby power	Max. load	Current limit for fault detection	Output voltage	Operation	Compatibility	Dimensions
TS98263	1 VA / 1 W	60 VA	10±5 mA	230 VDC	Maintained /non-maintained	<ul style="list-style-type: none"> <li>Operation mode can be selected by a DIP switch</li> <li>Intelligent Controller</li> <li>Local Controller module</li> </ul>	98 x 41 x 21 mm
TS98263B	1 VA / 1 W	60 VA	5±2.5 mA	230 VDC	Maintained /non-maintained	<ul style="list-style-type: none"> <li>Operation mode can be selected by a DIP switch</li> <li>Intelligent Controller</li> <li>Local Controller module</li> </ul>	98 x 41 x 21 mm
TS98253	1 VA / 1 W	100 VA	10±5 mA	230 VDC	Maintained /non-maintained	<ul style="list-style-type: none"> <li>Operation mode can be selected by a DIP switch</li> <li>Intelligent Controller</li> <li>Local Controller module</li> </ul>	98 x 41 x 21 mm
TS98253B	1 VA / 1 W	100 VA	10±5 mA	230 VDC	Maintained /non-maintained	<ul style="list-style-type: none"> <li>Operation mode can be selected by a DIP switch</li> <li>Intelligent Controller</li> <li>Local Controller module</li> <li>Slim model</li> </ul>	142 x 30 x 25 mm
TS98254	1 VA / 1 W	200 VA	10±5 mA	230 VDC	Maintained /non-maintained	<ul style="list-style-type: none"> <li>Operation mode can be selected by a DIP switch</li> <li>Intelligent Controller</li> <li>Local Controller module</li> </ul>	150 x 44 x 32 mm
TS98271	2 VA / 2 W	200 VA	10±5 mA	N/A	N/A	<ul style="list-style-type: none"> <li>Dimming for the emergency light operation</li> <li>DALI</li> <li>Intelligent Controller</li> </ul>	150 x 43 x 32 mm
TS98281	1.5 VA / 1.5 W	200 VA	10±5mA	220–240 V, 50/60 Hz AC, DC	Maintained /non-maintained	<ul style="list-style-type: none"> <li>Operation mode can be selected by a DIP switch</li> <li>Phase control input</li> <li>Switch control input</li> <li>Intelligent Controller</li> <li>Local Controller module</li> </ul>	150 x 43 x 32 mm
TS98255	2 VA / 2 W	625 VA	400 mA	230 VDC	Maintained /non-maintained	<ul style="list-style-type: none"> <li>Operation mode can be selected by a DIP switch</li> <li>Local Controller module</li> </ul>	150 x 44 x 32 mm

Please note that the compatibility of the DALI driver depends on the manufacturer and product and cannot always be guaranteed

# Ease of use through remote monitoring solutions

Further information about the MyTeknoware cloud service on pages 20-21

A remote monitoring system allows the centralised monitoring of multiple central battery units. We offer a solution meeting your requirements when you want to bring your emergency lighting system to the next level, in small as well as large projects.

This and the following spread give you information about our remote monitoring systems. If you need help in the choice of system or with anything related to emergency lighting, we are ready to help you with our local partners. An emergency lighting expert answers your call or email.



**MyTeknoware** cloud service allows the centralised monitoring of emergency lighting in your properties in one portal. Wherever, whenever. MyTeknoware allows safe, flexible and fast management. Read more about the MyTeknoware cloud service on pages 20-21

# Advanced Central Monitoring & Web Advanced Central Monitoring software (ACM & WebACM)

## Remote monitoring software for the property-specific monitoring of several central battery systems

Advanced Central Monitoring (ACM) and Web Advanced Central Monitoring (WebACM) are remote management suites for our addressable central battery systems. Both ACM and WebACM can be used for the simultaneous monitoring of up to 150 central battery systems. Both suites are intended for property-specific remote monitoring. They are similar in most ways, but ACM uses its own, separate network (RS485), while WebACM operates over the Ethernet.

ACM and WebACM allow the placement of luminaires and central battery units in the property's floor plans. The remote monitoring software shows the status of the central battery unit and the luminaires connected to it as well as the test log. Both suites require a Windows terminal device and Java support to operate. In case of deviations, both ACM and WebACM automatically send email to the addresses specified by the user.

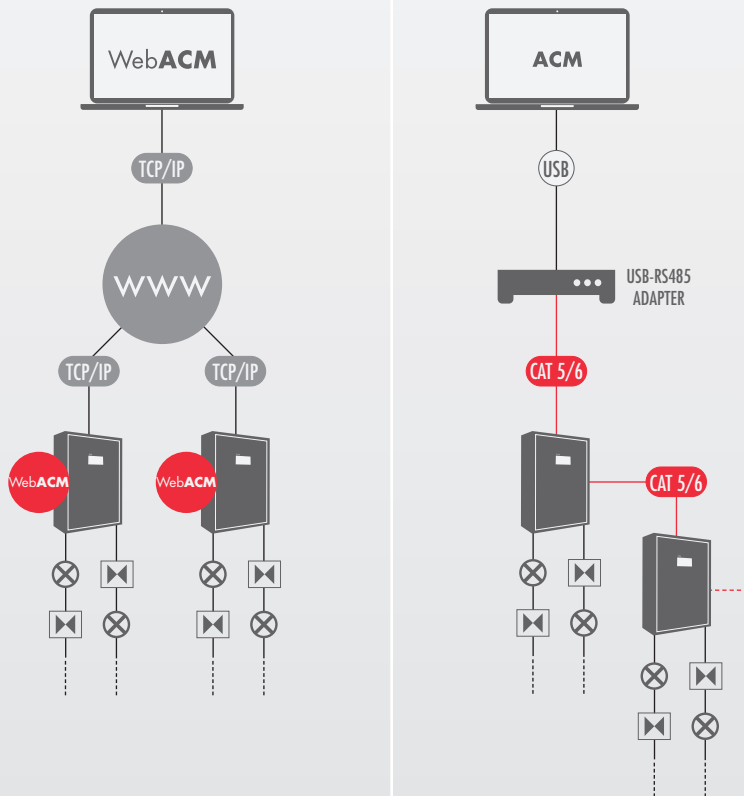

# MyTeknoware cloud service

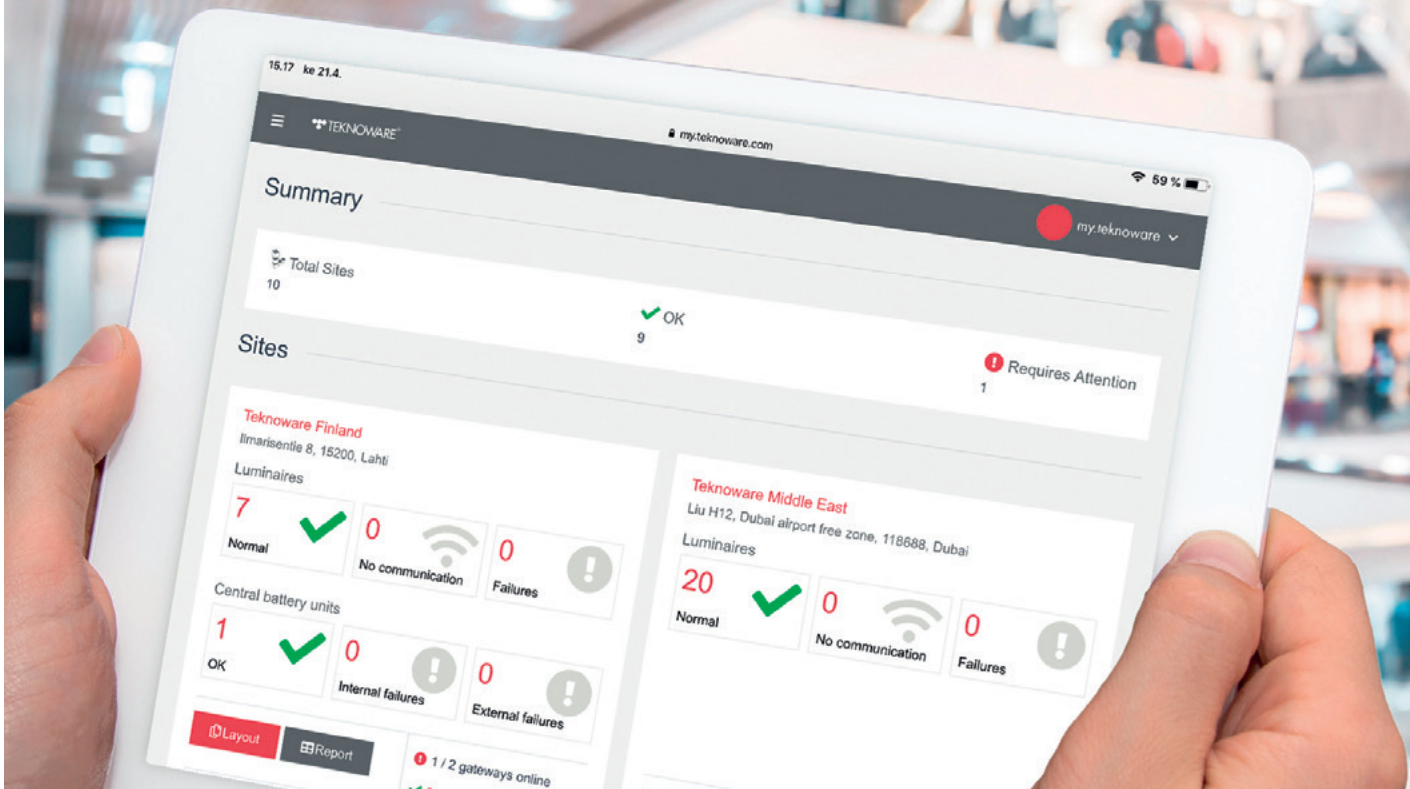

MyTeknoware is a management and reporting solution for emergency lighting systems showing the status of them all in all of your properties at one time. This portal is provided as a cloud service, allowing you to sign in anywhere at any time without a separate software suite. MyTeknoware monitors the emergency lighting systems on your behalf and sends notifications to your email at the intervals of your choice.



You no longer need a separate terminal for remote monitoring or on-site visits for manual system checks. You only need an Internet connection and your mobile device or computer to use MyTeknoware. The simple user interface shows you the status of all your emergency lighting systems in the home view as well as any fault reports in real time regardless of the scope of the system. In addition to MyTeknoware licence, there's no initial investments needed prior taking the service into us. Just connecting MyTeknoware to a compatible Teknoware emergency lighting system is enough.



# Why MyTeknoware?

## **All the data is available, quick and easy**

An overview of your emergency lighting systems in the portal. If you want to, you can also subscribe to summaries and alarms directly to your email. You can monitor the emergency lighting systems in your properties using any terminal device regardless of the time and location.

## **Saves time and money in maintenance operations**

service shows the status of your emergency lighting systems and the location and type of the luminaires in the property. This allows you to take the necessary spare parts with you and eliminates the need for unnecessary inspection rounds.

## **A safe way to meet the requirements of the authorities**

A cloud service is a safe and easy way to collect and save the maintenance and test logs required by the authorities. MyTeknoware is based on the Amazon AWS system, which guarantees information security and the required updates.

## A COMPREHENSIVE SOLUTION WITHOUT SOFTWARE AND ADDITIONAL COSTS



**The browser-based solution guarantees that you can enter the portal at any time, anywhere**  
Separate software suites are no longer needed. You just need a terminal device, MyTeknoware licence, your user credentials and an Internet connection.



**Controlling of self-contained and centrally supplied emergency lighting systems via a single portal**  
You can use the same interface to control different types of systems. An unlimited number of emergency lighting systems and properties can be connected to the cloud service.



**An unlimited number of users at different levels**  
An unlimited number of users with different levels of privileges can easily be added to the service. It ensures that each user can only see the information required and cannot modify settings without the required rights.



**A future-proof system**  
We are continuously updating the cloud service and ensuring its safety. You can be sure that your data is safe in the future as well.

## Batteries (18 x TEAxx / xxAh)

Product code	Battery capacity (Ah)	Max total load, 1 h operation time (W)	Max total load, 3 h operation time (W)	Battery cabinet	Battery cable	Dimensions of the battery (mm)	Weight of the battery (kg)
TEA020	6,5	870	350	TK6500B(P)	XJ997B	151 x 65 x 102	2,5
TEA021	15	1700	770	TK6500B(P)	XJ997B	183 x 79 x 169	5,7
TEA022	24	2720	1250	TK6500B(P) x 2	XJ997C	167 x 177 x 126	7,9
TEA023	38	4550	2050	TK6500B(P) x 2	XJ997C	199 x 167 x 172	12,2
TEA024	65	7500	3340	TKT6500(P) x 3	XJ997E	350 x 169 x 180	19,2
TEA024B	100	11780	5050	TKT6500(P) x 3	XJ997E	305 x 168 x 228	30,8
TEA024D	150	17670	7580	TKT6600P x 2	XJ997H	485 x 172 x 240	47
TEA024C	200	23300	10010	-	-	522 x 238 x 240	65
2 x TEA024D	300 (2 x 150)	25500	15160	-	-		
2 x TEA024C	400 (2 x 200)		19600	-	-		
3 x TEA024D	450 (3 x 150)		22740	-	-		

| A 10% reserve is recommended for the loads (W) mentioned in the table

## Battery cabinets

Product code	Battery capacity (V/Ah)	Protection rating (IP)	Weight (kg)
TK6500B	18 x 12 / 15	20	14
TK6500BP	18 x 12 / 15	34	19
TKT6500	6 x 12 / 100	20	28
TKT6500P	6 x 12 / 100	34	35
TKT6600P	9 x 12 / 150	34	56

## Battery cables

Product code	Length of the battery cable (m)	For
XJ997B	1,5	6.5 Ah batteries
XJ997	1,5	≥ 15 Ah batteries
XJ997C	2,5	Two battery cabinets
XJ997E	3,5	Three battery cabinets
XJ997H	3	Two battery cabinets

## Optional features

Product code	Product description	For
TST7750	IC-interface	7-series
TST7504, TST7508, TST7516, TST7524	Terminal block*	75C, 76C and 78C-
TST7724, TST7732, TST7740, TST7748, TST7756, TST7764, TST7772	Terminal block*	77C
TST7741	150 Ah auxiliary charger	77C

| \* Separate DIN rail output connectors. By default, the output circuits are connected directly to the changeover modules.

## Central monitoring options

Product code	Product description	For
TWC1000	MyTeknoware licence	7-series
TST5161	WebACM software	7-series
TST5131	ACM software	7-series



## LET THERE BE CONFIDENCE.

People tend to take the presence of light for granted. We take it seriously. Our passion for finding the best interior solution or lighting for our customers' needs is the foundation which unites our three businesses. The Bus & Coach and Rail Divisions aim to increase our customer vehicles' comfort, safety and functionality. The Emergency Lighting Division is innovating new means and measures to improve the safety and usability of buildings and cruise ships.

Teknoware is your local partner. We employ over 500 experts in 8 countries, and our sales network serves customers in over 50 countries. Our head office and largest production facilities are located in Finland, and our other world-class production units are located in the UK, Malaysia, Poland and the US.

Teknoware is part of the Teknower Group.

**Teknoware – made in Lahti, Finland.**

